

**LE ISTRUZIONI
PER IL BAGNO FUNZIONALE**

**THE INSTRUCTIONS
FOR THE FUNCTIONAL BATHROOM**

**LES INSTRUCTIONS
POUR LA SALLE DE BAIN
FUNCTIONNELLE**

X I L O N



I L

B A G N O

F U N Z I

O N A L E

IT

Leggere le istruzioni prima di iniziare l'installazione. Il manuale deve essere conservato per futura consultazione e per tutto il ciclo di vita del mobile e trasferito ad ogni successivo proprietario del prodotto.

CONTROLLO MERCE - Controllare attentamente la merce scaricata verificando l'integrità della merce ricevuta. Eventuali reclami per difetti di fabbricazione, abrasioni, ammaccature o rotture varie sono contestabili entro 8 gg. dal ricevimento della merce consegnata presso il nostro rivenditore, non dopo che il mobile è già stato installato.

DATI TECNICI - XILON srl si riserva la facoltà di apportare tutte le modifiche che riterrà opportune, tali da non pregiudicare le caratteristiche essenziali del prodotto descritto o illustrato. Essi potranno risultare nelle forme e nell'aspetto diversi dal campione pur nel pieno rispetto sostanziale delle caratteristiche di funzionalità.

CONFORMITA' PRODOTTO - La corrispondenza del prodotto rispetto al campione non deve intendersi in senso tassativo, dato che sussistono margini di tolleranza dovuti a variazioni del prodotto o del campione (colori, materiali, misure), causate da fattori ambientali (umidità, luce, ecc...). La conformità dei campioni vale soprattutto per marmi o legni i quali possono presentare delle variazioni di colore e venatura dovute al prodotto naturale.

INSTALLAZIONE DEL PRODOTTO - La ditta XILON srl declina ogni responsabilità per errata o cattiva installazione del prodotto fornito, sia esso di sua fabbricazione o di terzi. Inoltre, consiglia di avvalersi di personale qualificato in rispetto delle norme in materia. L'installazione corretta del prodotto garantisce la maggior durata nel tempo dello stesso.

ENG

Read the instructions before starting the installation. Keep the manual with you for further consultation throughout the service life of the furniture and leave it to eventual next owners of the product.

GOODS CHECK – Check carefully the goods verifying the integrity of the received products. Eventual complaints for manufacturing defects, abrasions, dents or cracking must be filed within 8 days from the receipt of the goods at your warehouse, not after the furniture has been installed.

TECHNICAL DATA – XILON srl reserves the right to make all the amendments it deems necessary, if they do not affect the essential features of the product described or illustrated. They could be different in shape or appearance from the sample, while the functional characteristics remain essentially unchanged.

COMFORMITY WITH THE SAMPLE - Conformity with the sample must not be understood to be peremptory, considering that margins of tolerance remain due to product or sample variations (colours, materials, dimensions), caused by environmental factors (humidity, light, etc...). Conformity of the samples apply especially to marbles or woods, which may feature colour and grain variations due to the nature of the product itself.

PRODUCT INSTALLATION - XILON srl declines liability for incorrect or improper installation of the product supplied, whether produced by XILON or by third parties. It also recommends hiring qualified personnel in compliance with the regulations in force. Correct product installation guarantees a longer product life span.

FR

Lisez les instructions avant de commencer l'installation. Gardez le manuel avec vous pour une consultation ultérieure pendant toute la durée de vie du mobilier et laissez-le aux éventuels futurs propriétaires du produit.

VÉRIFICATION DES MARCHANDISES – Vérifiez soigneusement les marchandises en contrôlant l'intégrité des produits reçus. D'éventuelles réclamations pour défauts de fabrication, abrasions, bosses ou fissures doivent être déposées dans les 8 jours suivant la réception des marchandises à votre entrepôt, et non après que le mobilier ait été installé.

DONNÉES TECHNIQUES – XILON srl se réserve le droit de faire toutes les modifications qu'elle juge nécessaires, tant qu'elles n'affectent pas les caractéristiques essentielles du produit décrit ou illustré. Elles peuvent être différentes en forme ou en apparence de l'échantillon, tandis que les caractéristiques fonctionnelles restent essentiellement inchangées.

CONFORMITÉ À L'ÉCHANTILLON – La conformité à l'échantillon ne doit pas être comprise comme péremptoire, considérant que des marges de tolérance subsistent en raison de variations du produit ou de l'échantillon (couleurs, matériaux, dimensions), causées par des facteurs environnementaux (humidité, lumière, etc...). La conformité des échantillons s'applique notamment aux marbres ou aux bois, qui peuvent présenter des variations de couleur et de grain en raison de la nature même du produit.

INSTALLATION DU PRODUIT – XILON srl décline toute responsabilité pour une installation incorrecte ou inappropriée du produit fourni, qu'il soit produit par XILON ou par des tiers. Elle recommande également de faire appel à du personnel qualifié en conformité avec les réglementations en vigueur. Une installation correcte du produit garantit une plus longue durée de vie du produit.

INDICE

1. POSIZIONE SCARICHI POSITION OF DRAINS	6
2. CALCOLO POSIZIONE PIASTRINE PER ATTACCAGLIE CALCULATION OF THE RIGHT POSITION OF PLATES FOR HANGERS	22
3. INDICAZIONI PER RINFORZO PARETI SUGGESTIONS TO STRENGTHEN THE WALL	23
4. FISSAGGIO MOBILI SOSPESI WALL-MOUNTED FURNITURE FIXING	24
5. FISSAGGIO MOBILI A TERRA FLOOR-MOUNTED FURNITURE FIXING	25
6. FISSAGGIO TOP TOP FIXING	26
7. FISSAGGIO LAVARREDO SOSPESO SUSPENDED WASHBASIN FIXING	27
8. FISSAGGIO LAVABO IN CERAMICA FIXING CERAMIC BASIN	30
9. FISSAGGIO MENSOLONI MENSOLONI FIXING	32
10. FISSAGGIO DEI PIEDINI FIXING OF THE FEET	33
11. REGOLAZIONI E FISSAGGIO PENSILI ADJUSTMENTS AND HANGING CABINET FIXING	35
12. ATTACCAIA PENSILI A GIORNO HANGRES OPEN SHELVING	36
13. FISSAGGIO SKEMA/ROAD SKEMA/ROAD FIXING	37
14. CASSETTI/ CERNIERE DRAWERS/ HINGES	41
15. LAUNDRY SHELF LAUNDRY SHELF	43
16. INFORMAZIONI AL CONSUMATORE CONSUMER INFORMATION	77

1. POSIZIONE SCARICHI POSITION OF DRAINS

1.1 LINEA 46 BASINBBASKET LINEA 46 BASINBBASKET

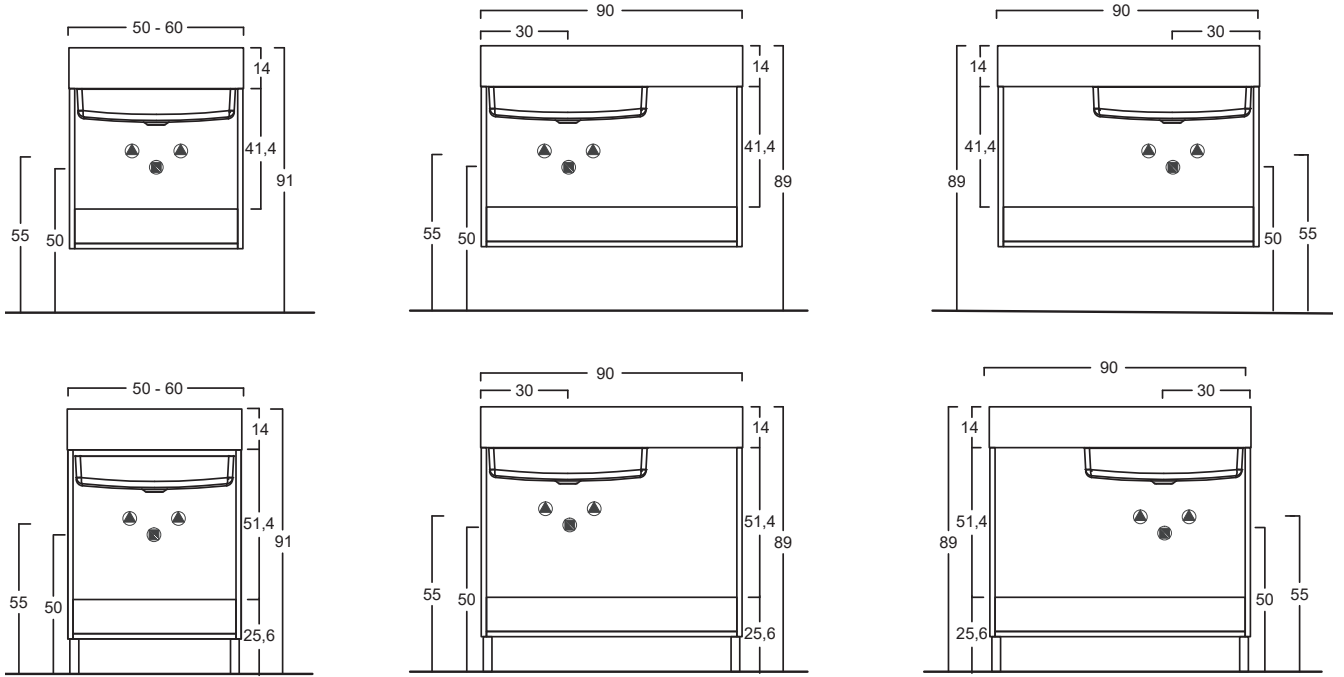

1.2 LINEA 46 CERAMICA LINEA 46 CERAMIC

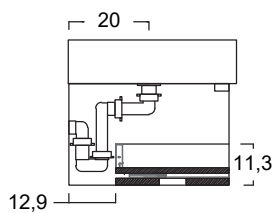
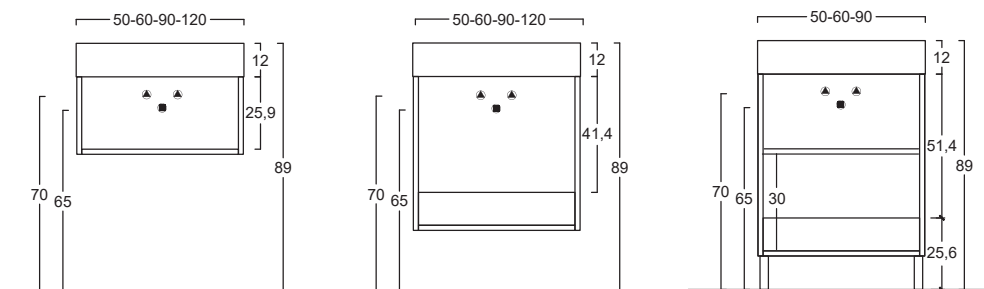

INGOMBRO CASSETTO PER BASI SOSPESSE
INGOMBRO CASSETTO PER BASI SOSPESSE

1.3 LINEA 46 OCRITECH
LINEA 46 OCRITECH

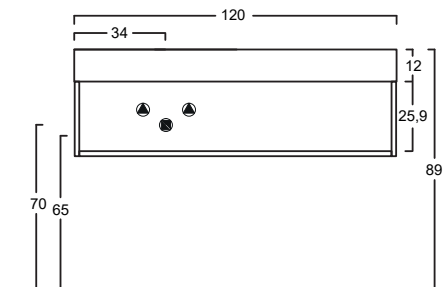
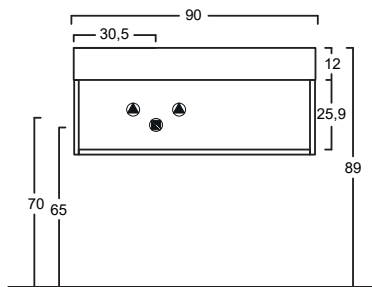
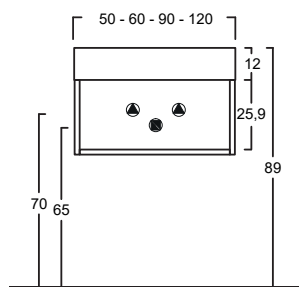

DX - SX

DX - SX

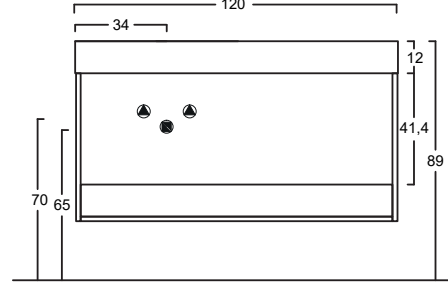
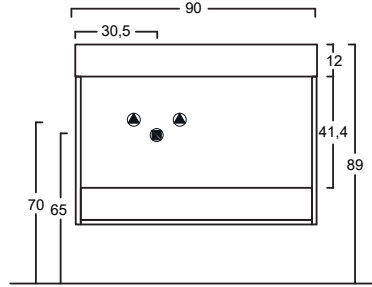
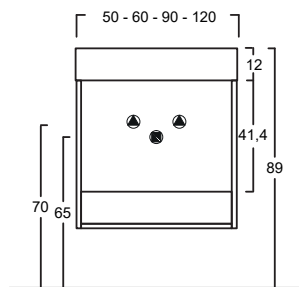

DX - SX

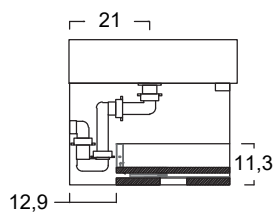
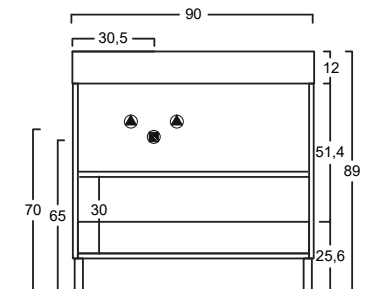
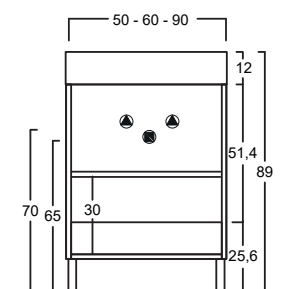

INGOMBRO CASSETTO PER BASI SOPPESE
INGOMBRO CASSETTO PER BASI SOPPESE

1.4 LINEA 26
LINEA 26

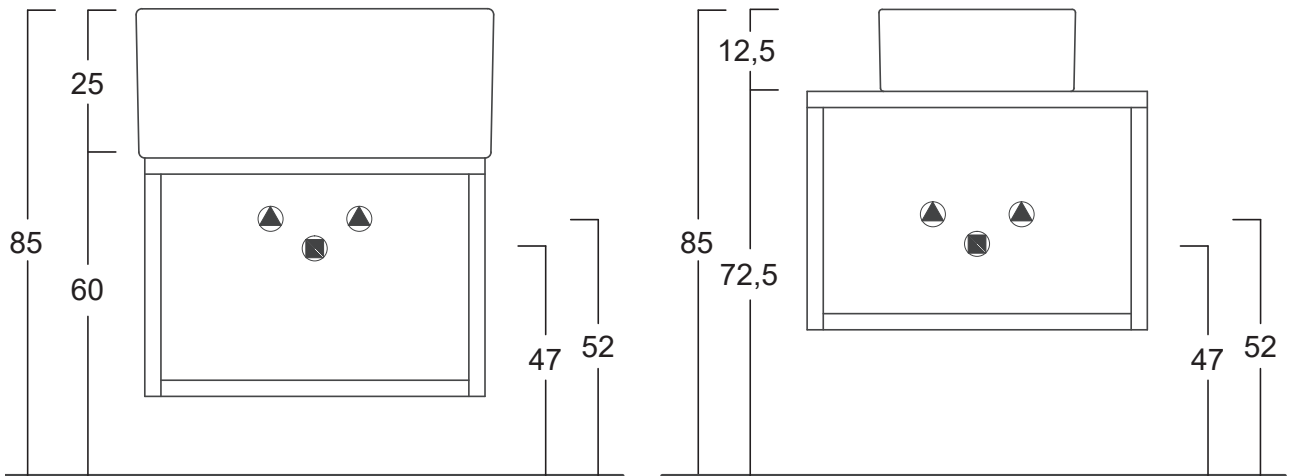

1.5 LINEA 55
LINEA 46 OCRITECH

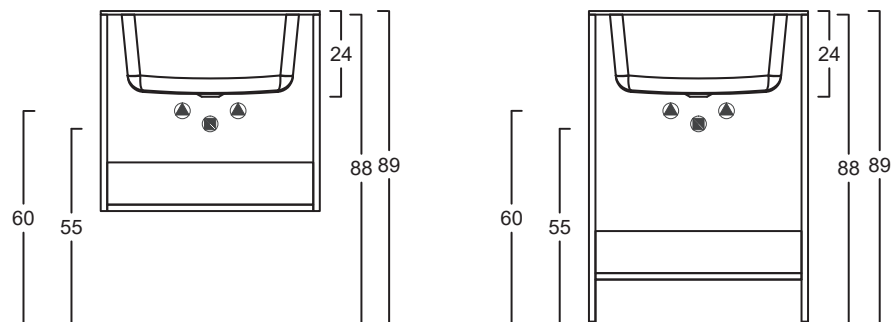

1.6 LINEA 55 NANCO+
LINEA 55 NANCO+

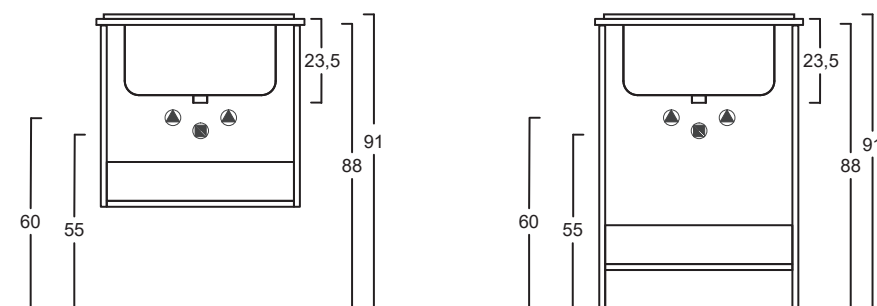

1.7 LINEA 55 GHOST
LINEA 55 GHOST

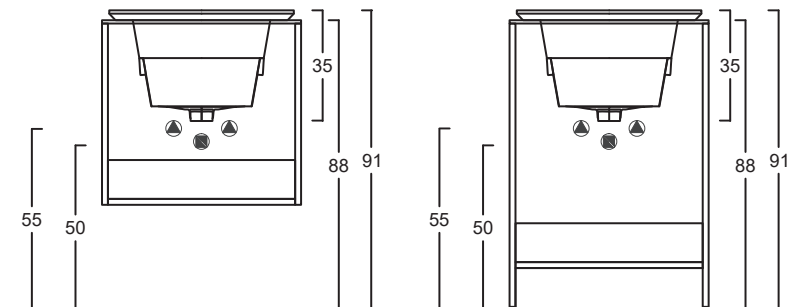

1.8 LAUNDRY SHELF GHOST
LAUNDRY SHELF GHOST

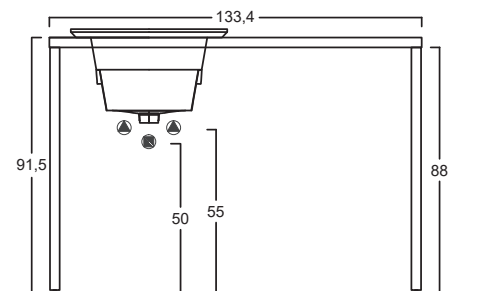

1.9 LAUNDRY SHELF NANCO+
LAUNDRY SHELF NANCO+

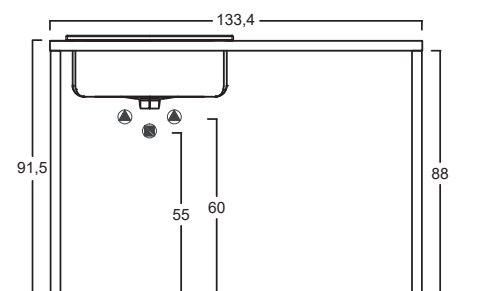

1.10 TOTUS NANCO

TOTUS NANCO

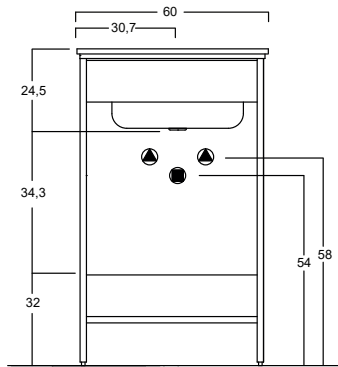
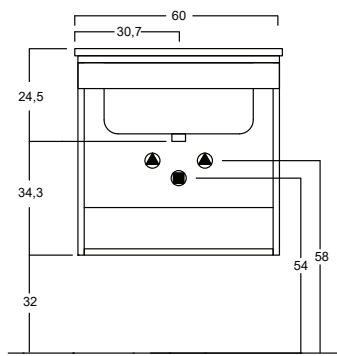

1.11 TOTUS OCRITECH

TOTUS OCRITECH

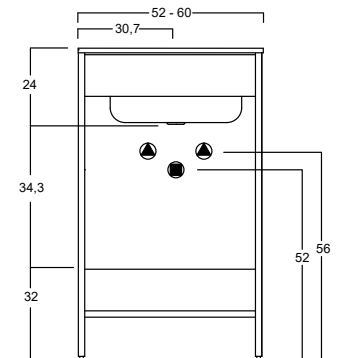
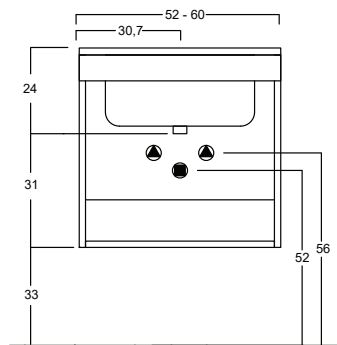

1.12 TOTUS MONOBLOCCHI
TOTUS MONOBLOCCHI

123x46-56-65

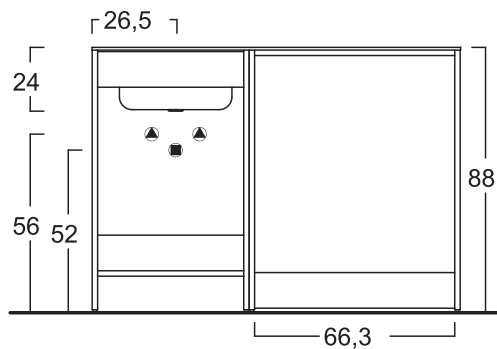

131x46-56-65

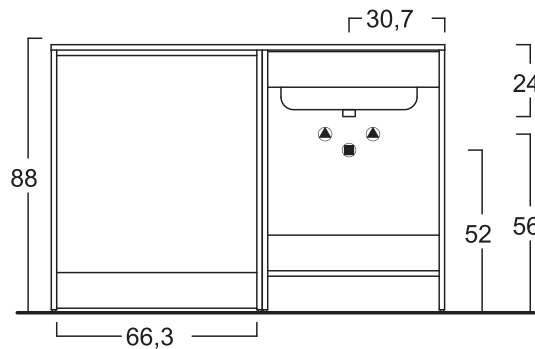

123x46-56-65

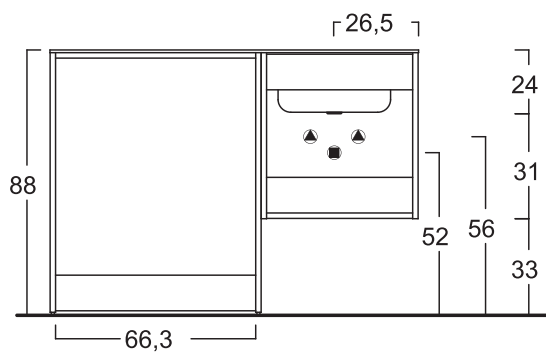

131x46-56-65

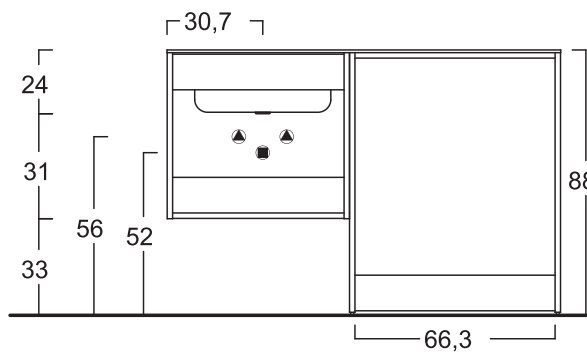

110x56

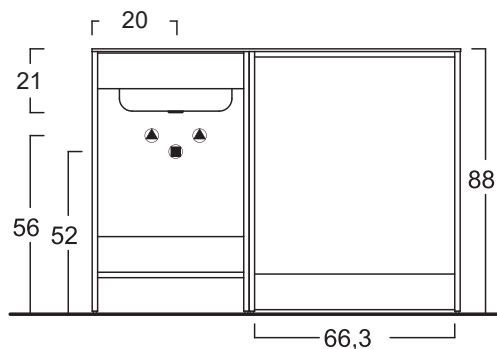

110x56

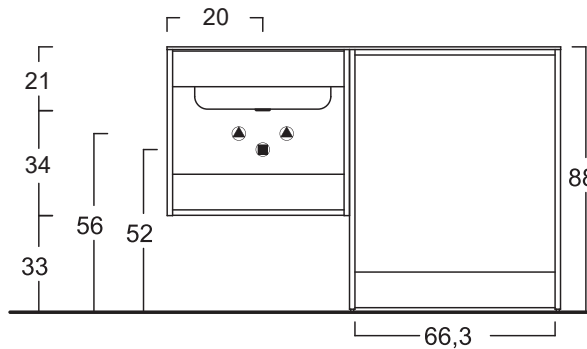

1.13 MENSOLONI OCRITECH
MENSOLONI OCRITECH

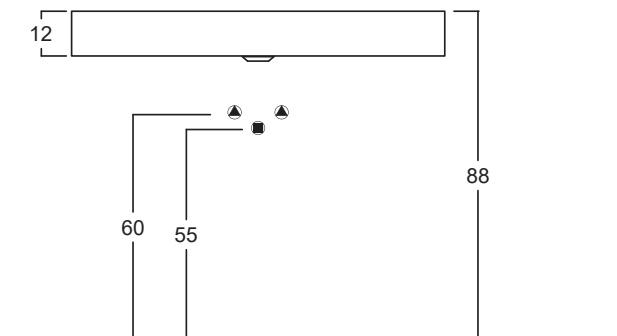

1.14 MENSOLONI CERAMICA
MENSOLONI CERAMIC

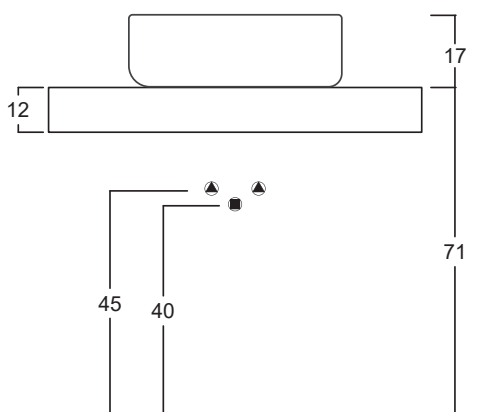
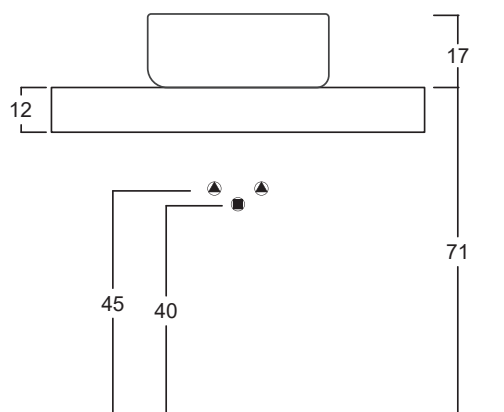

1.15 MENSOLONI VETRO
MENSOLONI GLAS

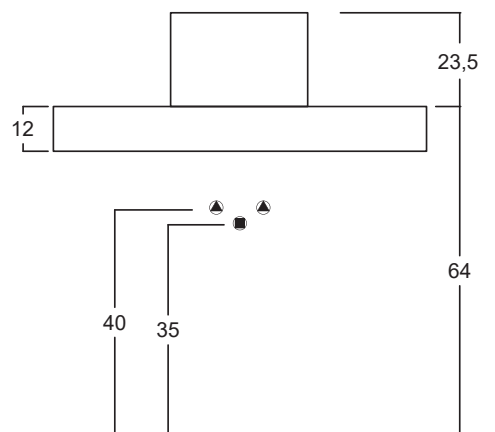
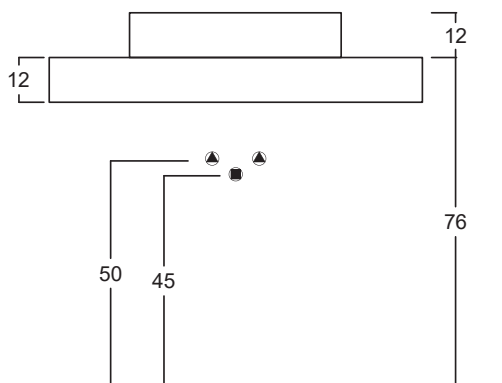

1.16 ALLUMINIUM NANCO+
ALLUMINIUM NANCO+

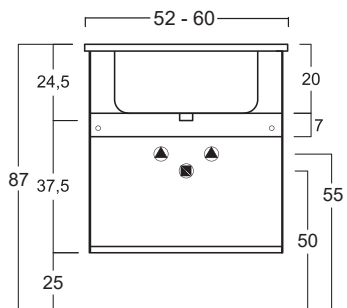

1.17 ALLUMINIUM CERAMICA
ALLUMINIUM OCRITECH

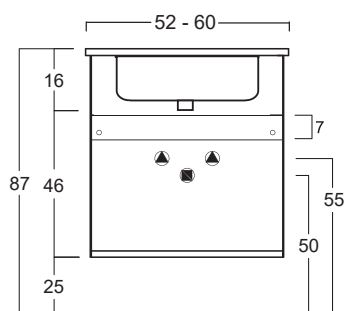

1.18 ALLUMINIUM CERAMICA APPOGGIO
ALLUMINIUM CERAMICA APPOGGIO

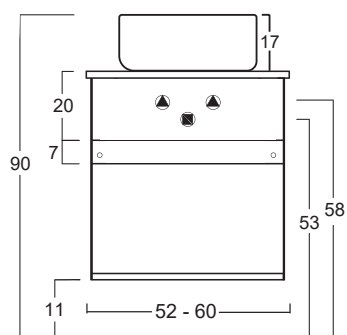

1.19 NANCO+
NANCO+

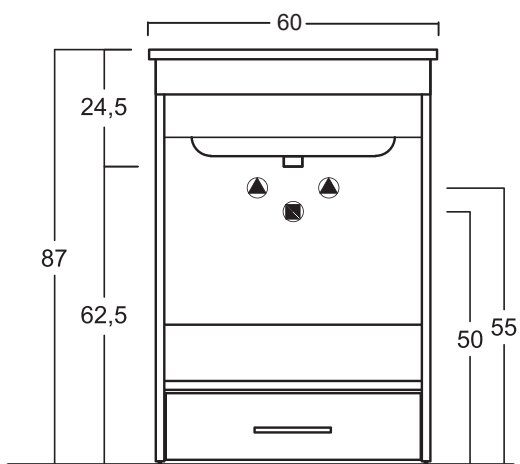
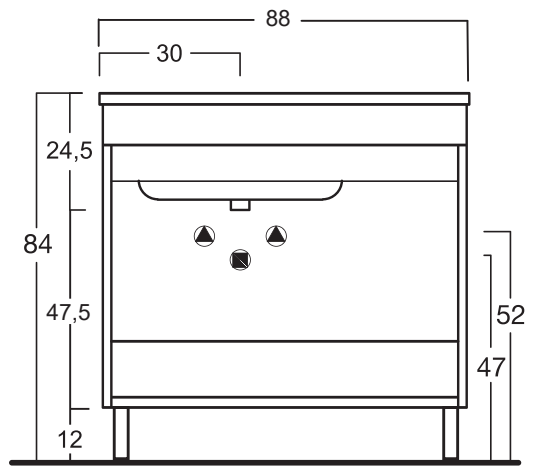
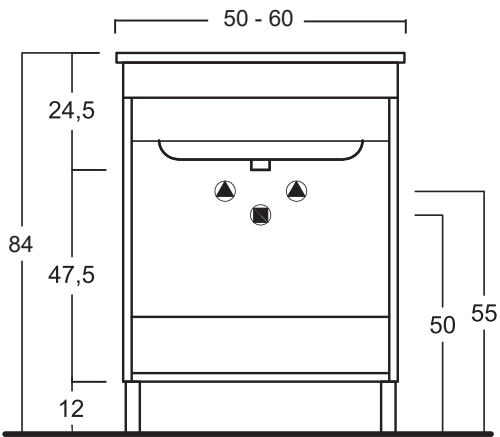
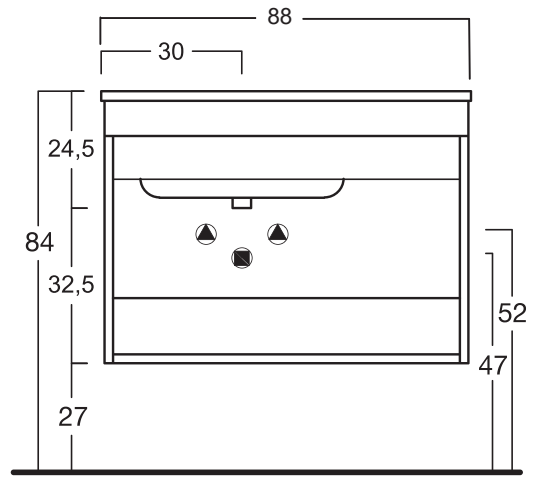
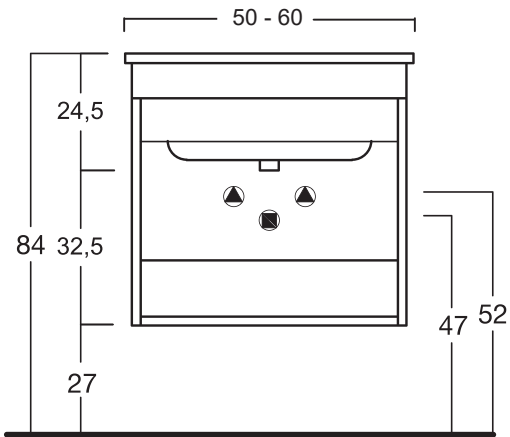

1.20 GHOST
GHOST

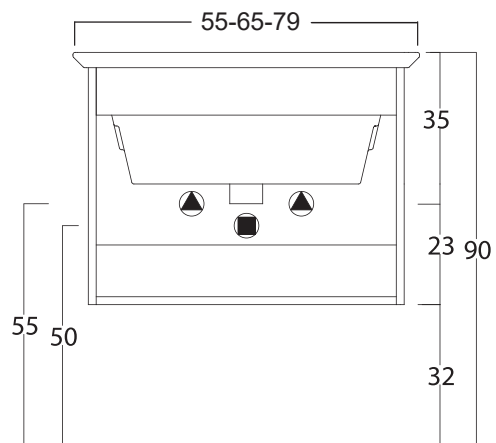
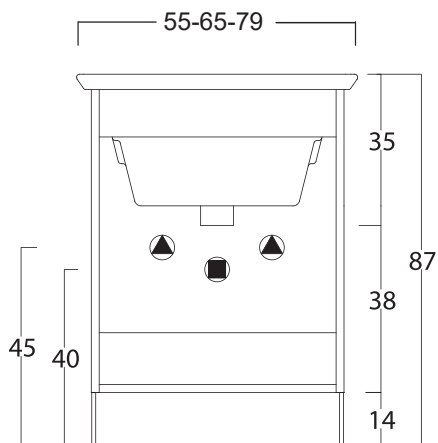

1.21 LAVAREDO
LAVARREDO

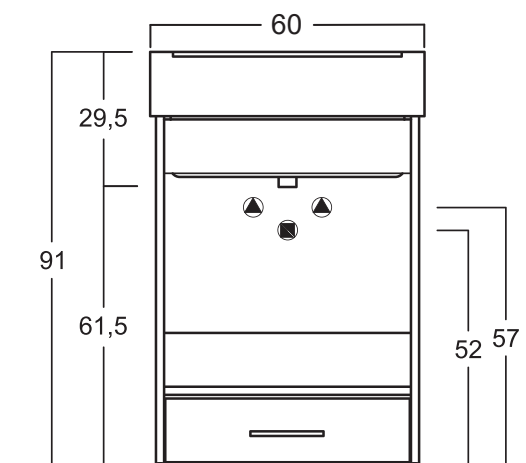
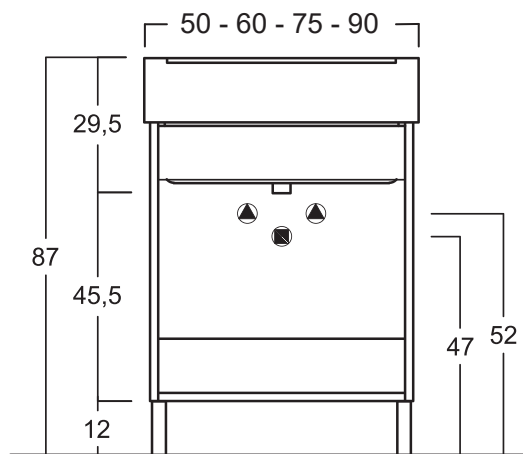
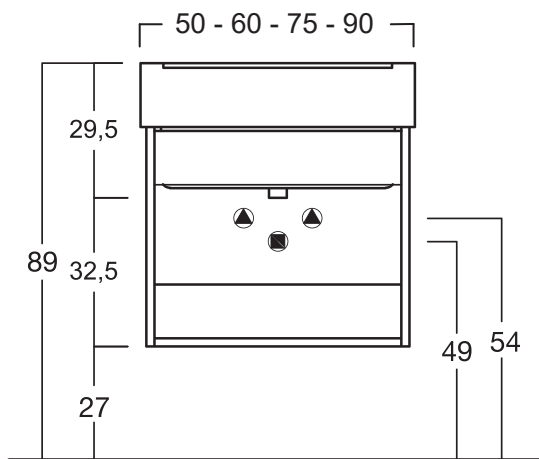

1.22 SKEMA
SKEMA

60X50 ART. 365N

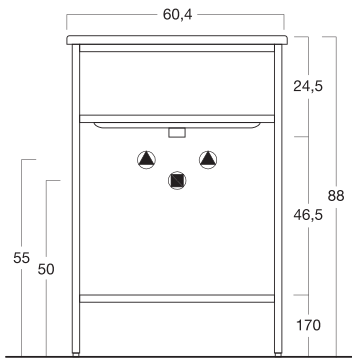

88X50 ART. 395N

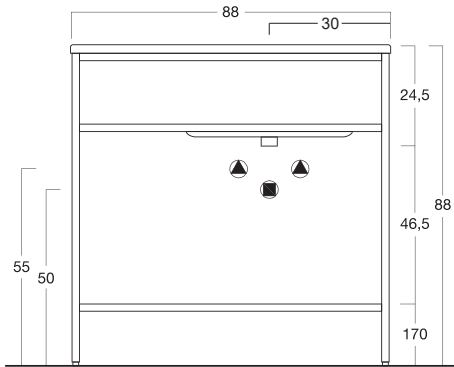

60X50 ART. 365CN

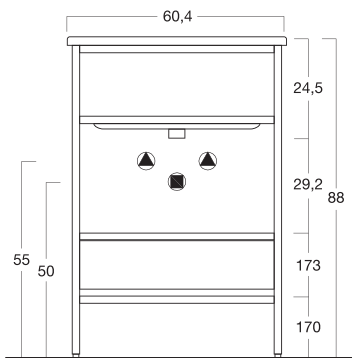

88X50 ART. 395CN

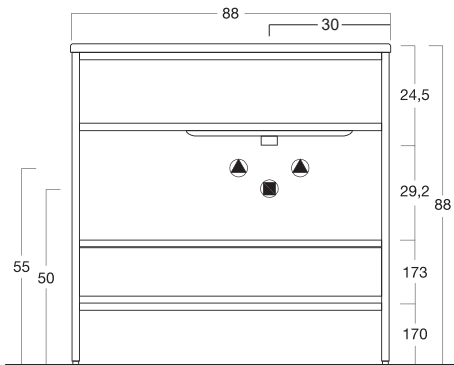

1.23 ICARO
ICARO

DX - SX

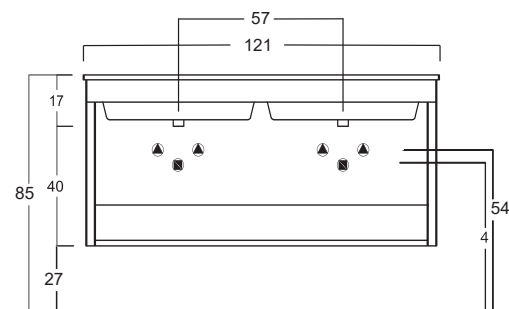
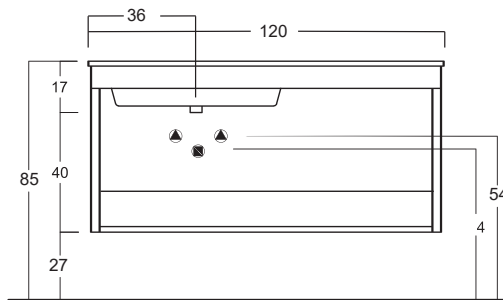
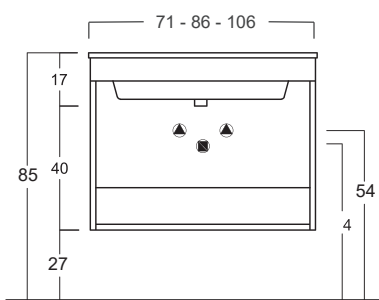

1.24 ICARO SMART
ICARO SMART

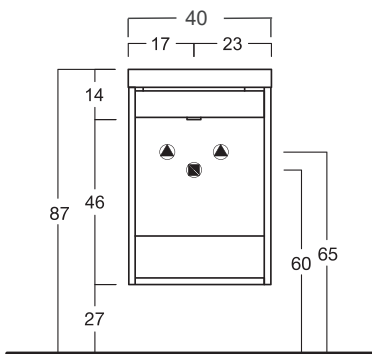

1.25 LAVAVI 60 - 80
BASIN 60 - 80

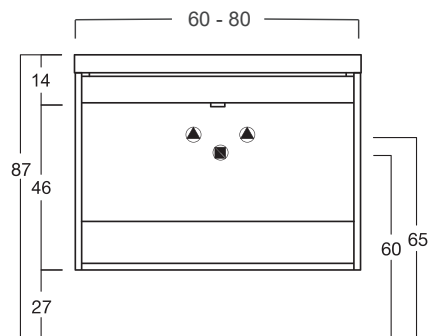

1.26 NANCO
NANCO

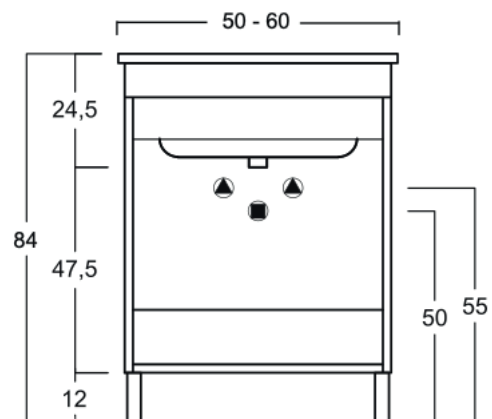

1.27 EKO
EKO

127X65 DX - SX

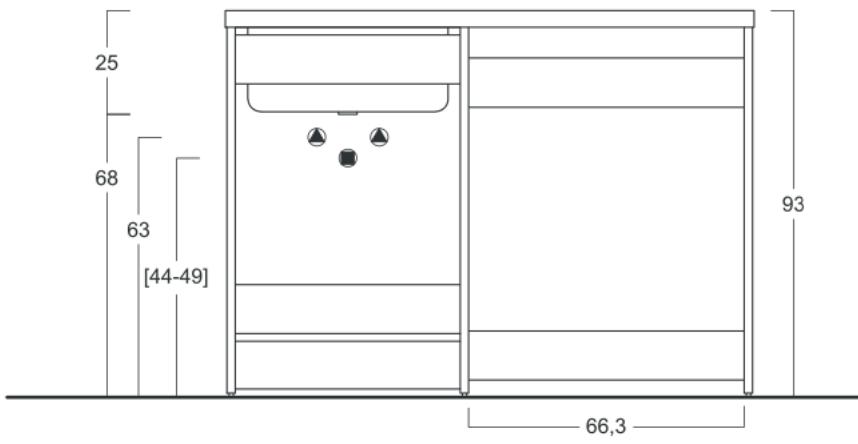

107X60 DX - SX

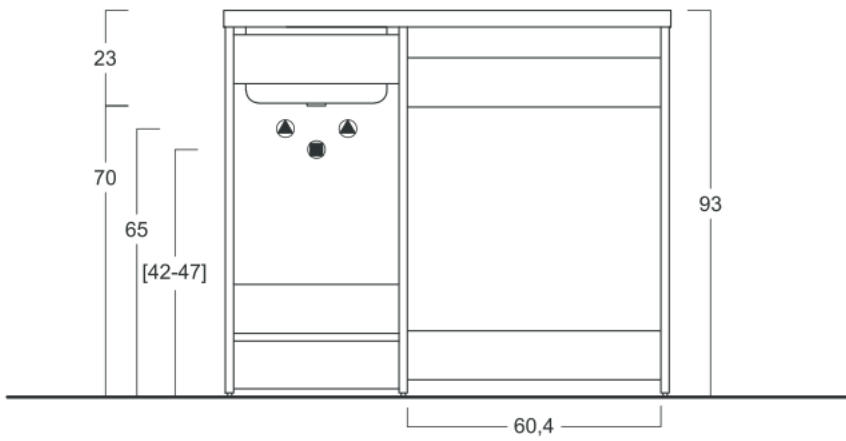

124X50 DX - SX

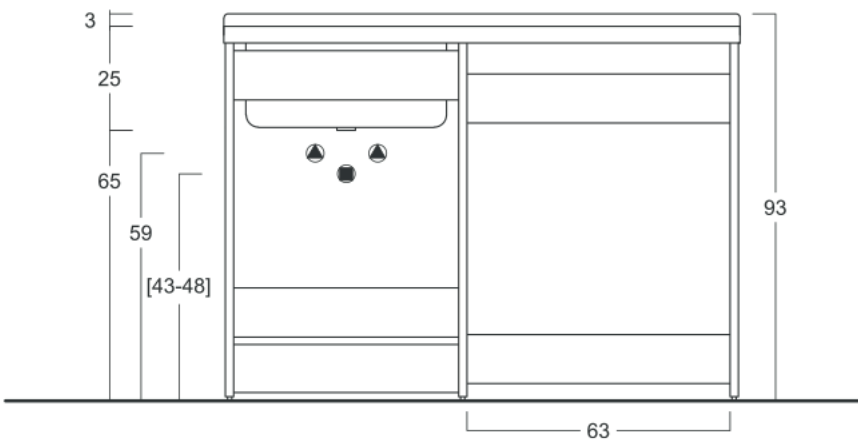

75X60 - 75X50 - 60X45 - 50X45 - 45X45

75X60 double sink
75X60 bivasca

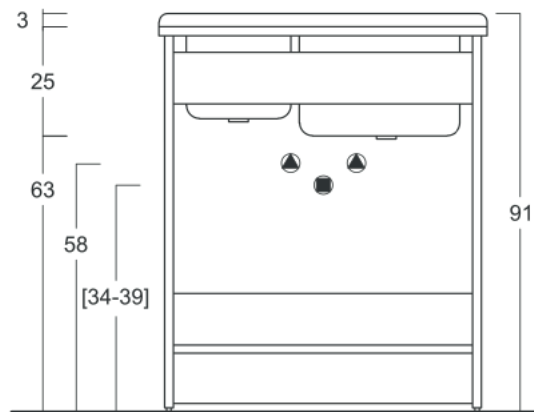
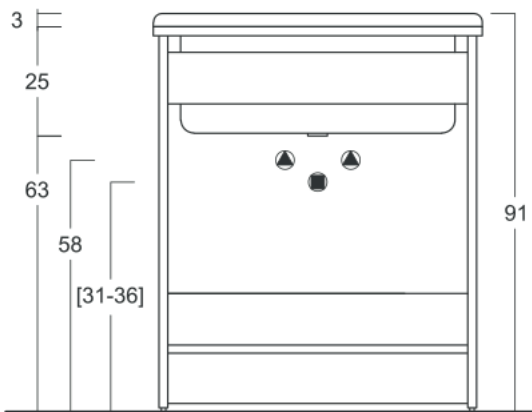

60X60 - 45x60 - 60x50 - 50x50 - 45x50

45x51 ceramica / **ceramic**
60X51 ceramica / **ceramic**
70X51 ceramica / **ceramic**

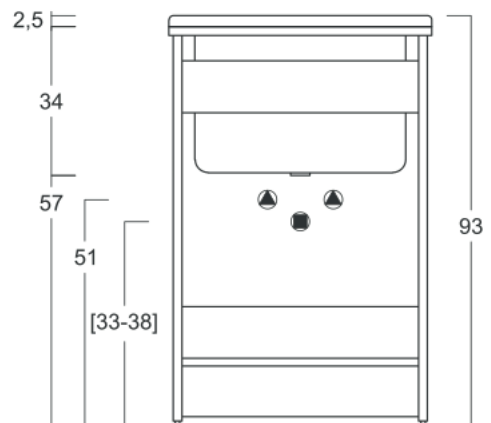
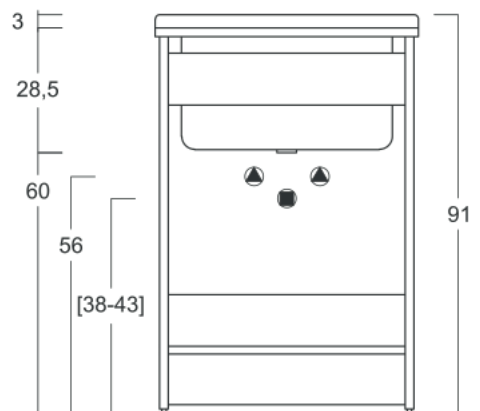

1.28 LAVANDERINA
LAVANDERINA

107X60 DX - SX

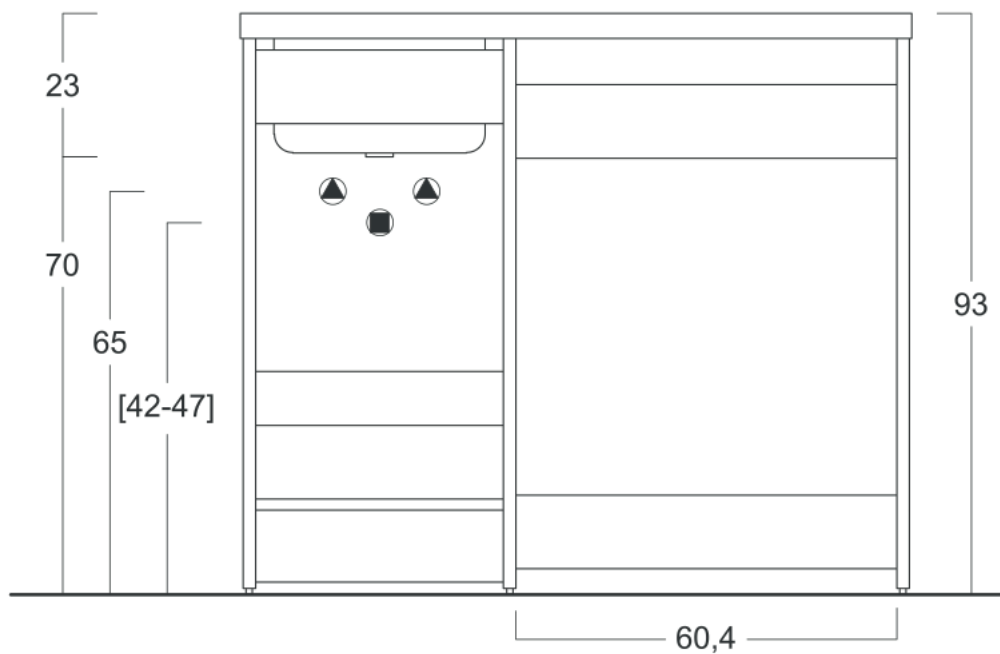

60X60 - 60X50 - 60X45 - 50X50 - 45X50

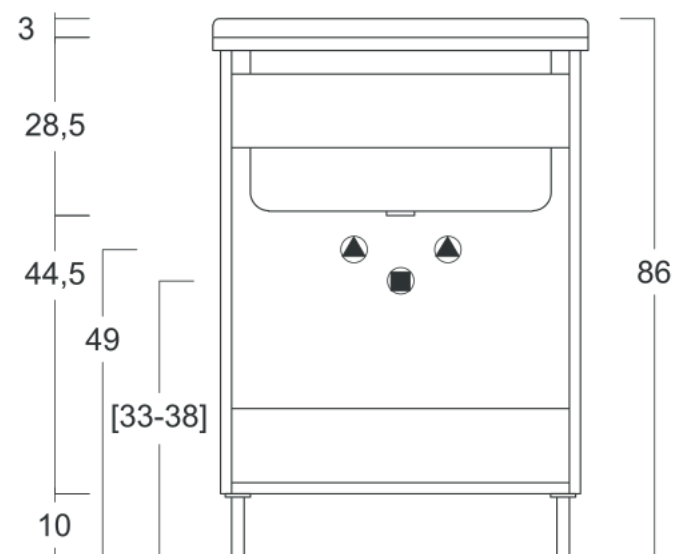

1.29 METEO
METEO

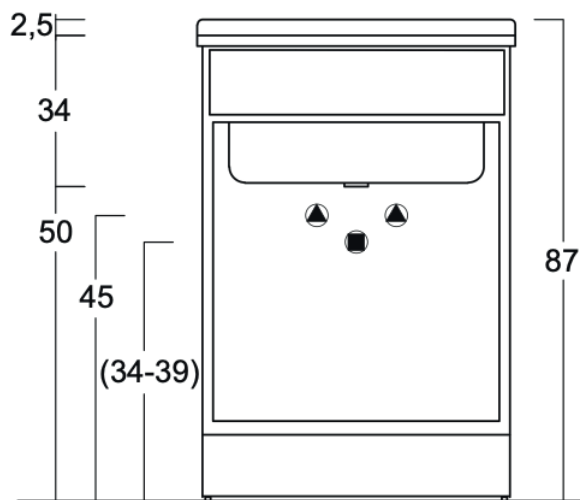

1.30 JOSÈ
JOSÈ

107X65

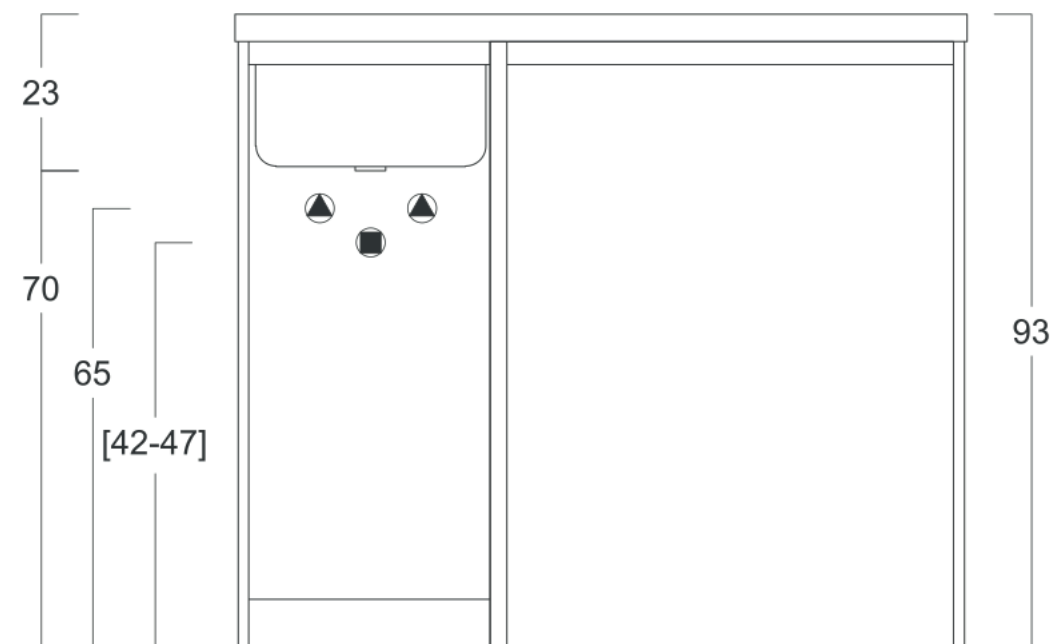

2. CALCOLO POSIZIONE PIASTRINE PER ATTACCAGLIE

CALCULATION OF THE RIGHT POSITION OF PLATES FOR HANGERS

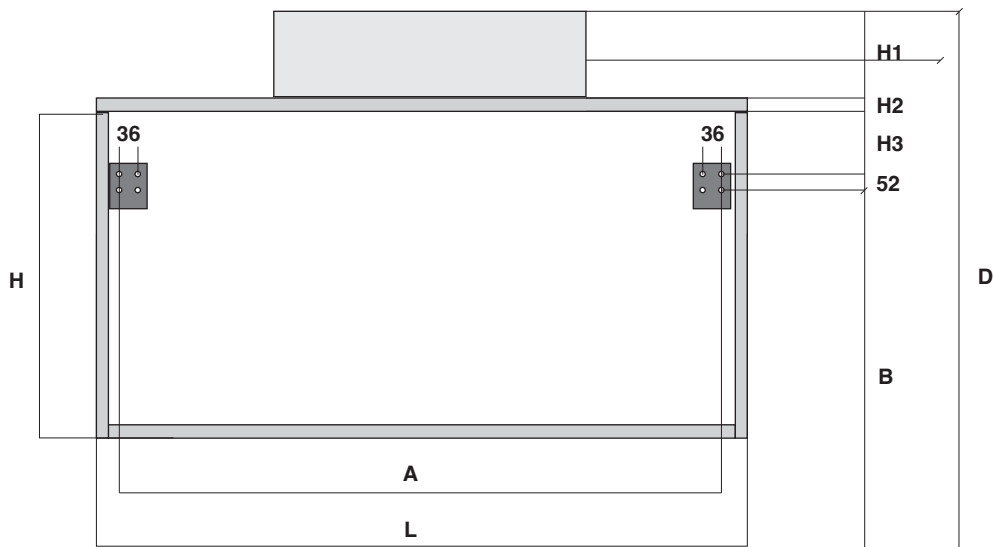

IT

A = Interasse fori piastra antisgancio
L = Larghezza totale della base
B = Altezza fori piastra antisgancio
D = Altezza totale
H = Altezza mobile
H1 = Altezza lavabo
H2 = Spessore top
H3 = Distanza filo superiore mobile ai fori piastra

$$A = L - 63 \text{ mm}$$

$$B = D - H1 - H2 - H3 - 52 \text{ mm}$$

H3 VARIANTI

H3 sottolavabo **H55 cm = 80 mm**
H3 sottolavabo **H28 cm = 80 mm**
H3 cassettiere e basi contenitive = **25mm**

FR

A = Entraxe des trous de la plaque anti-détachement
L = Largeur totale de la base
B = Hauteur des trous de la plaque anti-détachement
D = Hauteur totale
H = Hauteur mobile
H1 = Hauteur du lavabo
H2 = Épaisseur du dessus
H3 = Distance du bord supérieur de l'unité aux trous de la plaque

$$A = L - 63 \text{ mm}$$

$$B = D - H1 - H2 - H3 - 52 \text{ mm}$$

H3 VARIANTES

H3 sous-lavabo **H55 cm = 80 mm**
H3 sous-lavabo **H28 cm = 80 mm**
H3 tiroirs et bases de rangement = **25 mm**

ENG

A = Distance between anti-detachment plate holes
L = Total width of the base
B = Height of anti-detachment plate holes
D = Total height
H = Movable height
H1 = Sink height
H2 = Top thickness
H3 = Distance from the top edge of the unit to the plate holes

$$A = L - 63 \text{ mm}$$

$$B = D - H1 - H2 - H3 - 52 \text{ mm}$$

H3 VARIANTS

H3 under-sink **H55 cm = 80 mm**
H3 under-sink **H28 cm = 80 mm**
H3 drawers and storage bases = **25 mm**

3. INDICAZIONI PER RINFORZO PARETI SUGGESTIONS TO STRENGTHEN THE WALL

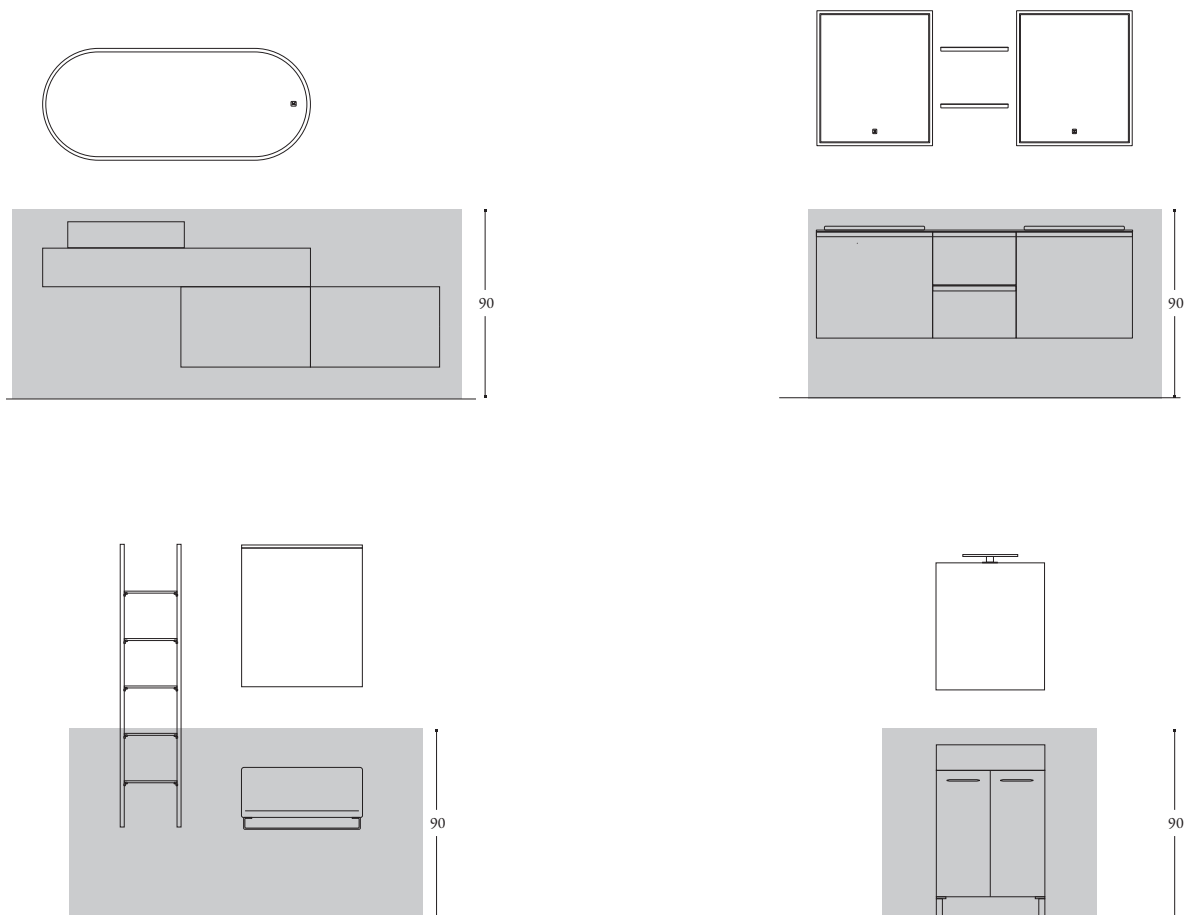

IT
Attenzione! Prima di installare qualsiasi mobile Xilon si prega di accertarsi della consistenza della parete, soprattutto nel caso in cui la composizione sia completamente sospesa. Previa verifica del vostro installatore, se necessario, si consiglia un rinforzo da terra fino ad altezza massima di 90 cm. Sono stati riportati alcuni esempi di composizioni tipo dove la porzione di parete da rinforzare è stata indicata in grigio.

ENG
Please Note! Before installing any Xilon furniture, we strongly advise you to check the consistency of the wall, especially in the case of wall-hung compositions. Upon verification, if necessary, we suggest to add a reinforced plate up to 90 cm height from the ground. In the pictures we show some typical compositions where we have highlighted in grey the concerned portion of the wall.

4. FISSAGGIO MOBILI SOSPESI WALL-MOUNTED FURNITURE FIXING

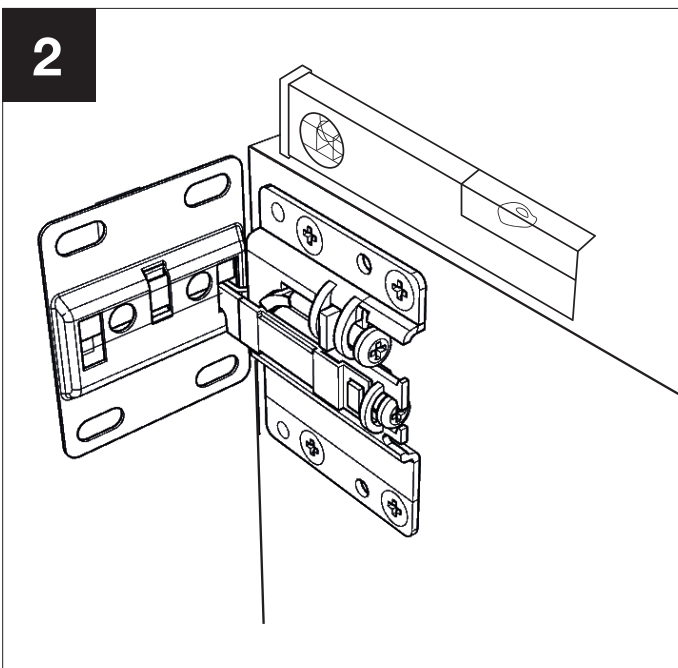
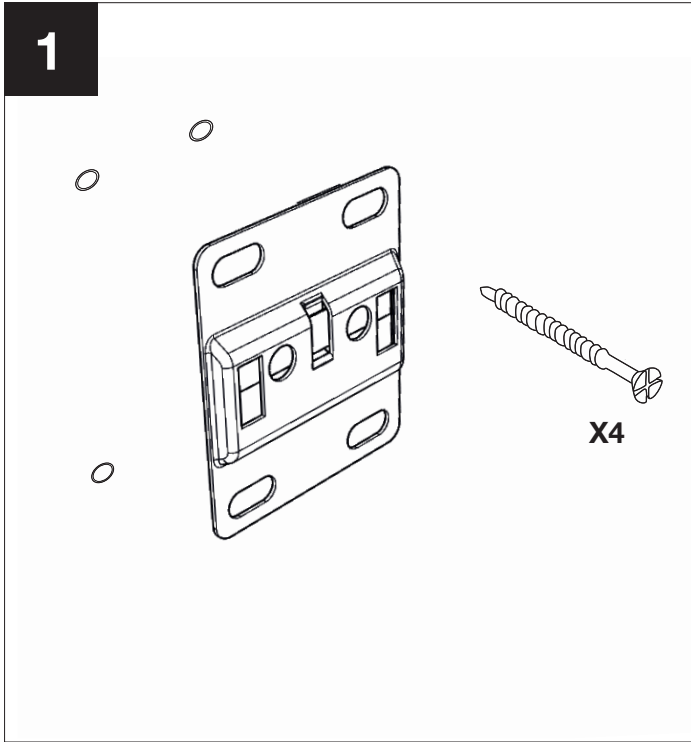

5. FISSAGGIO MOBILI A TERRA FLOOR-MOUNTED FURNITURE FIXING

Fissare alla parete il mobile con i fissaggi ad "L" in dotazione
Secure the furniture to the wall using the supplied L-shaped brackets.

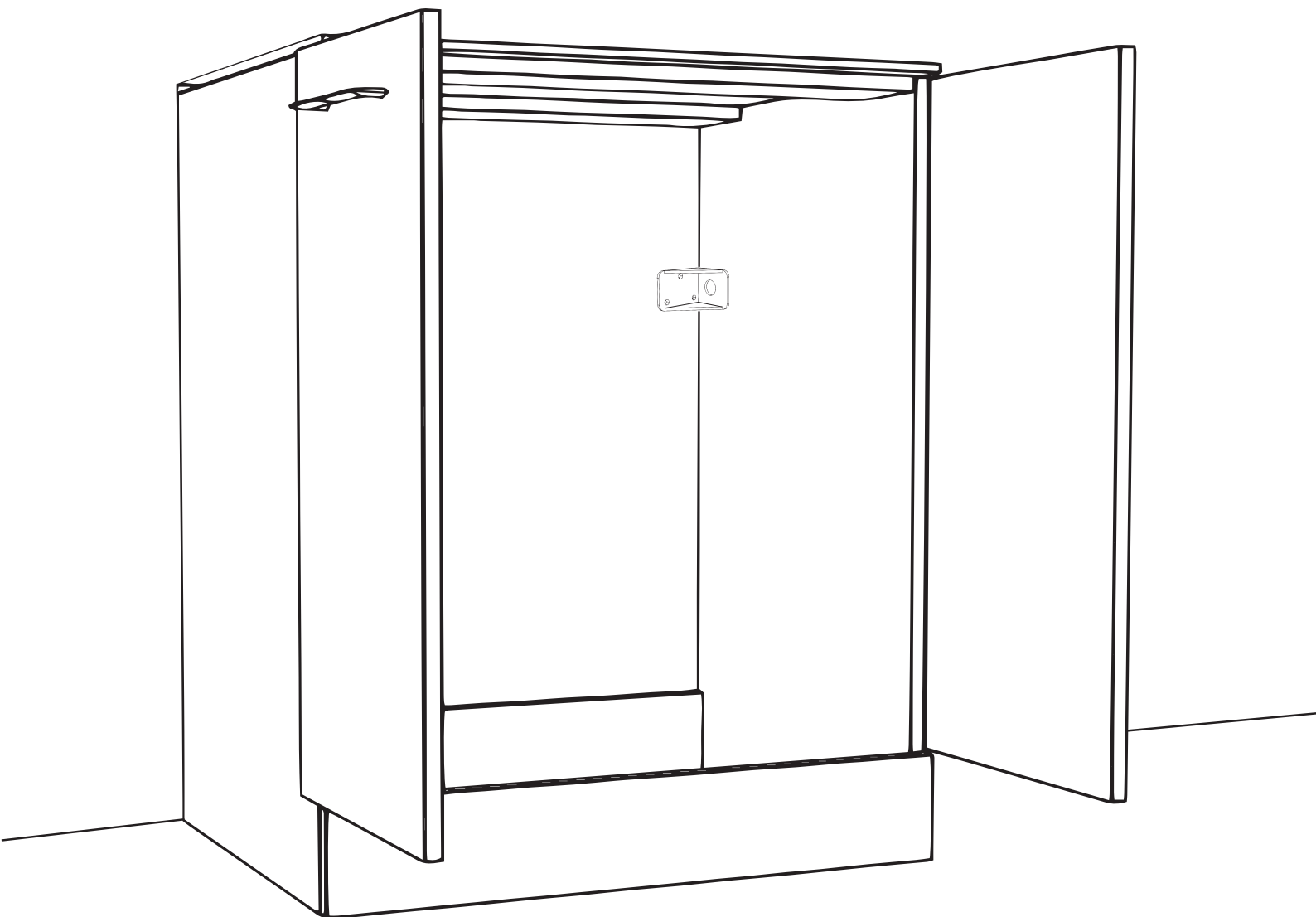

6. FISSAGGIO TOP
TOP FIXING

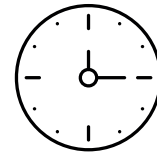

24H

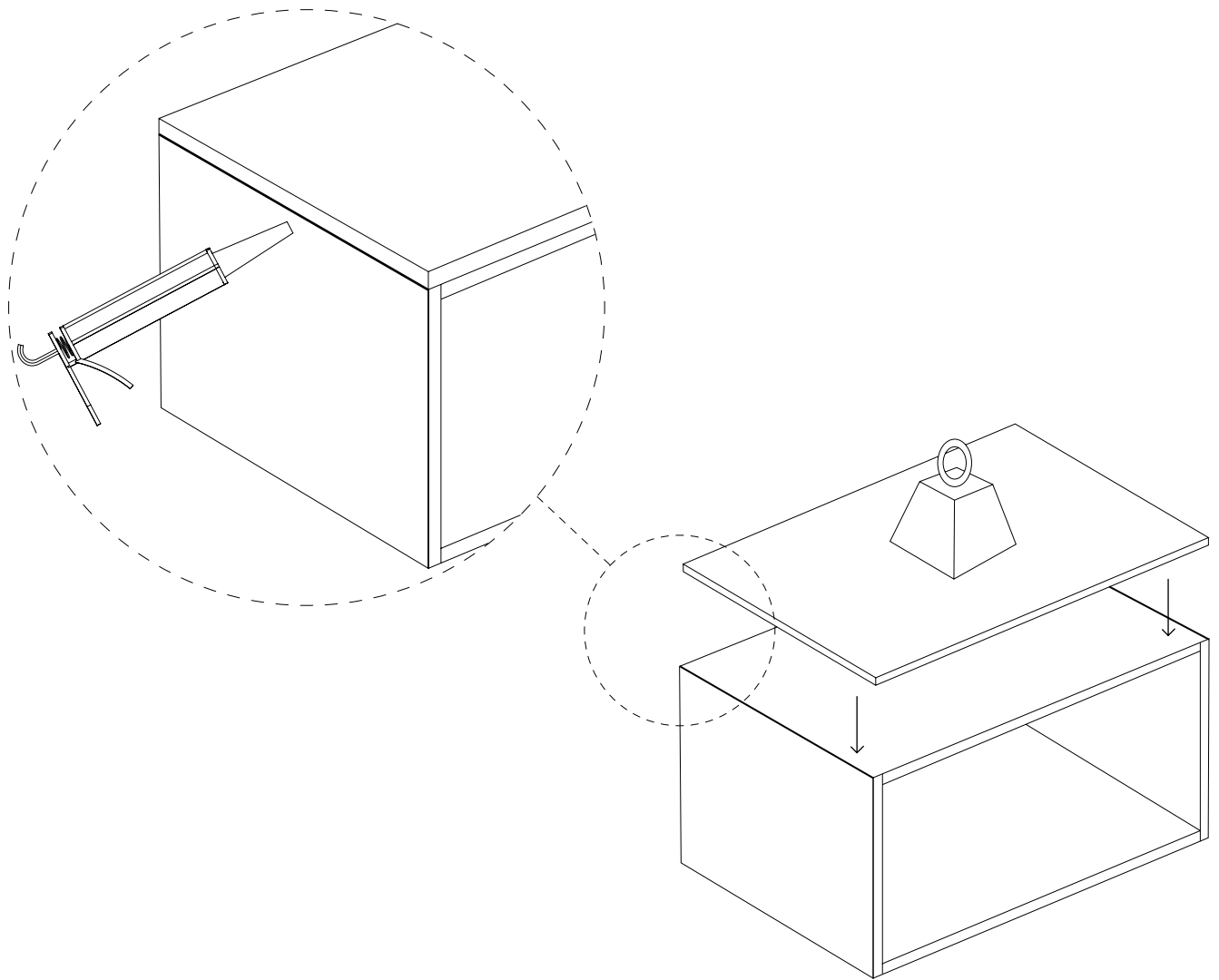

7. FISSAGGIO lavabi libera installazione
SUSPENDED WASHBASIN FIXING

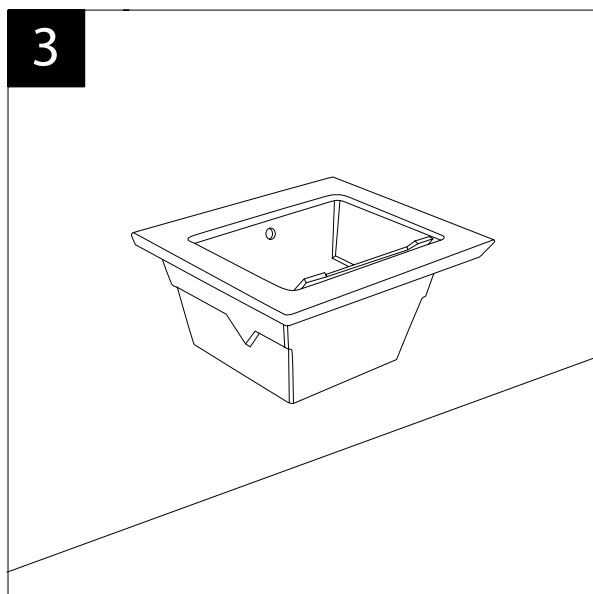
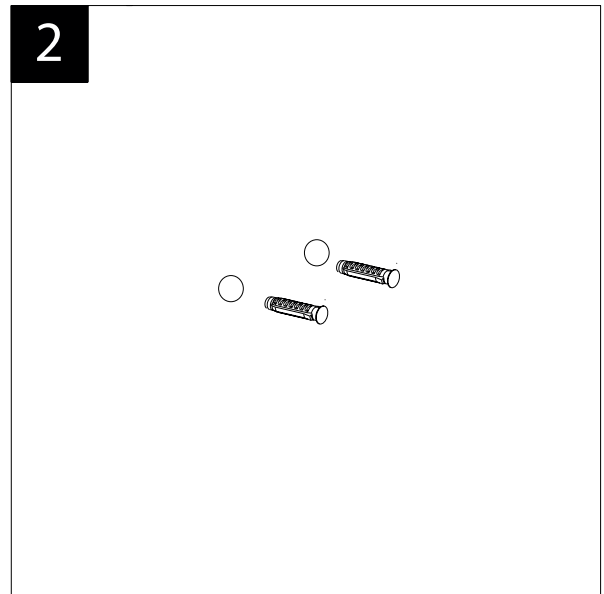
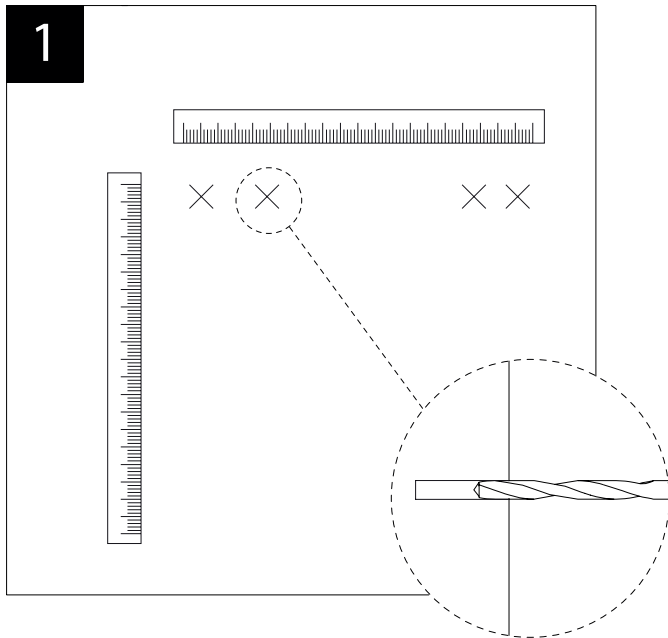

7.1 LAVARREDO CON MOBILE

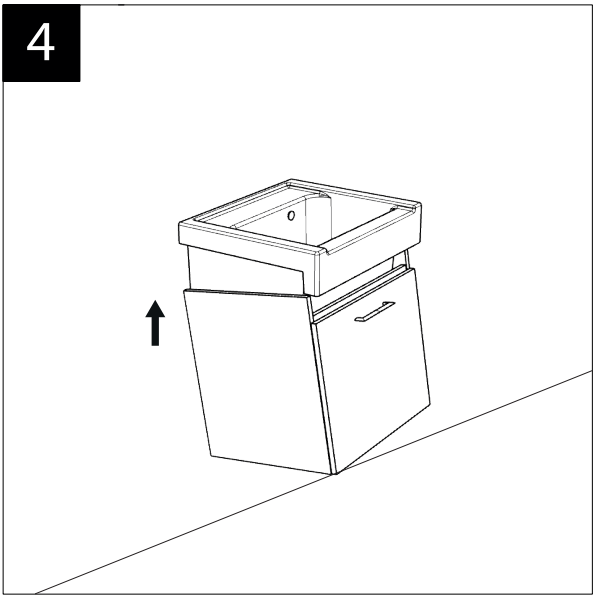
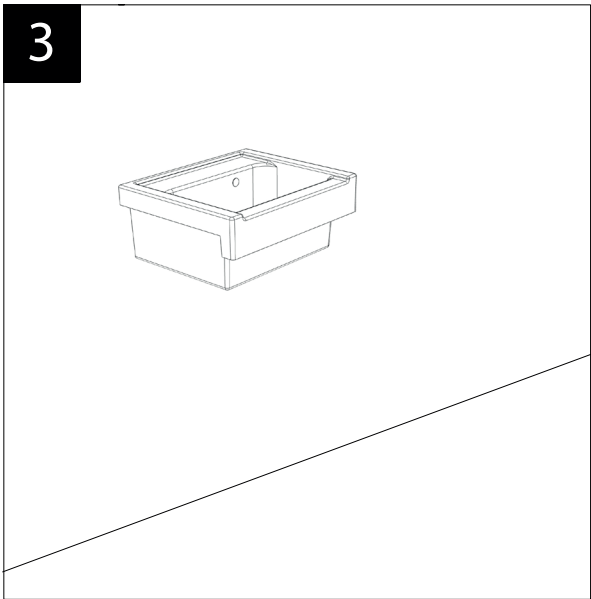
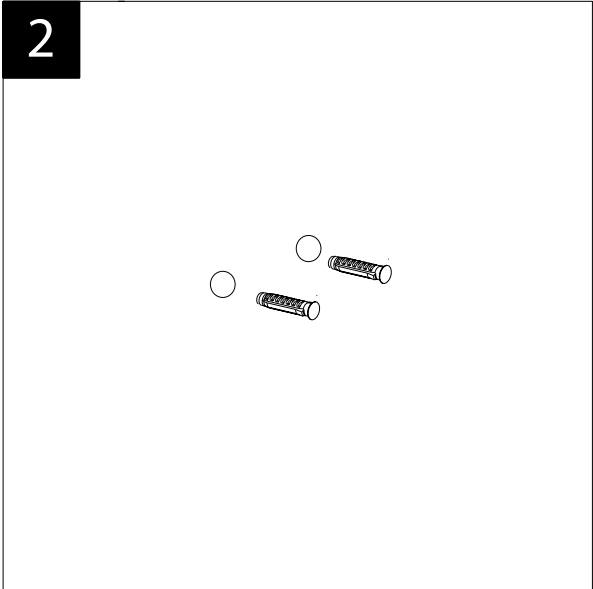
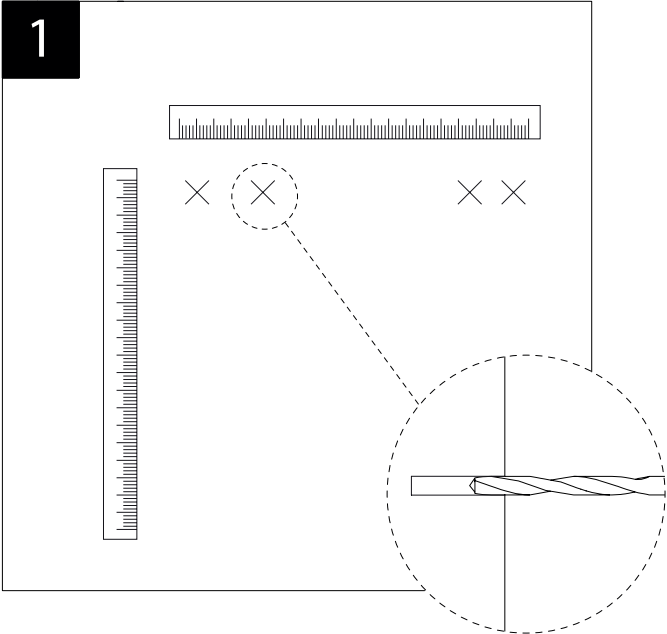

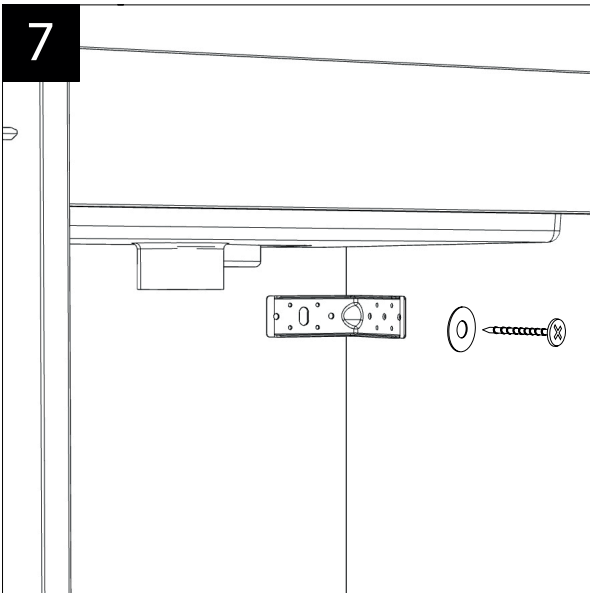
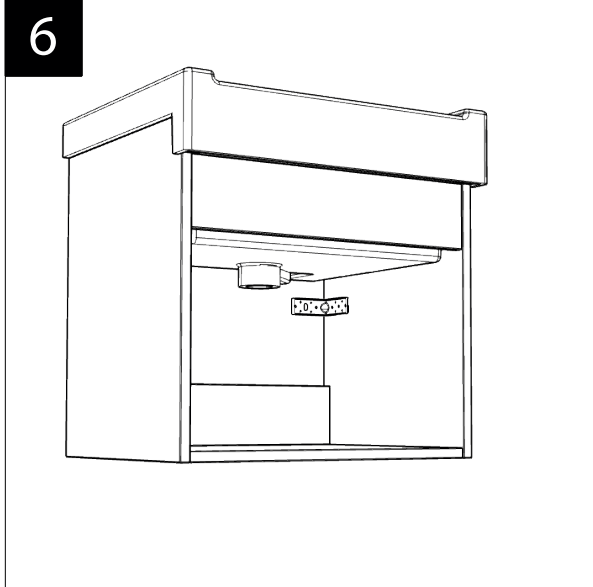
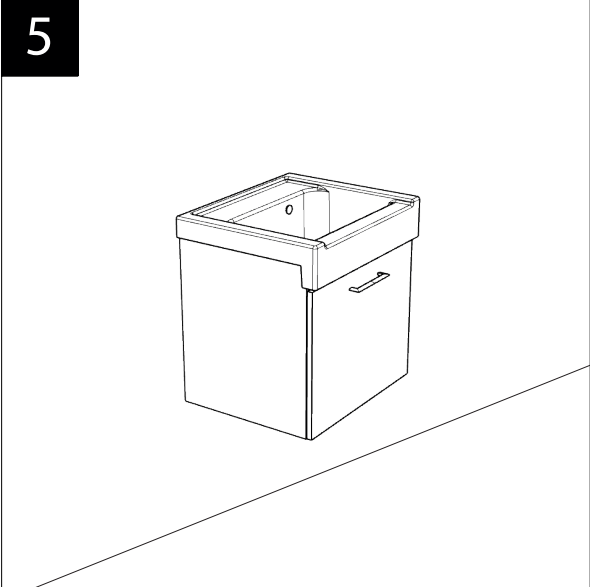

8. FISSAGGIO LAVABO IN CERAMICA
FIXING CERAMIC BASIN

8.1. LAVABI CERAMICA APPOGGIO
LAVABI CERAMICA APPOGGIO

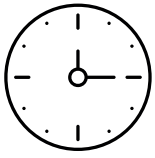

24H

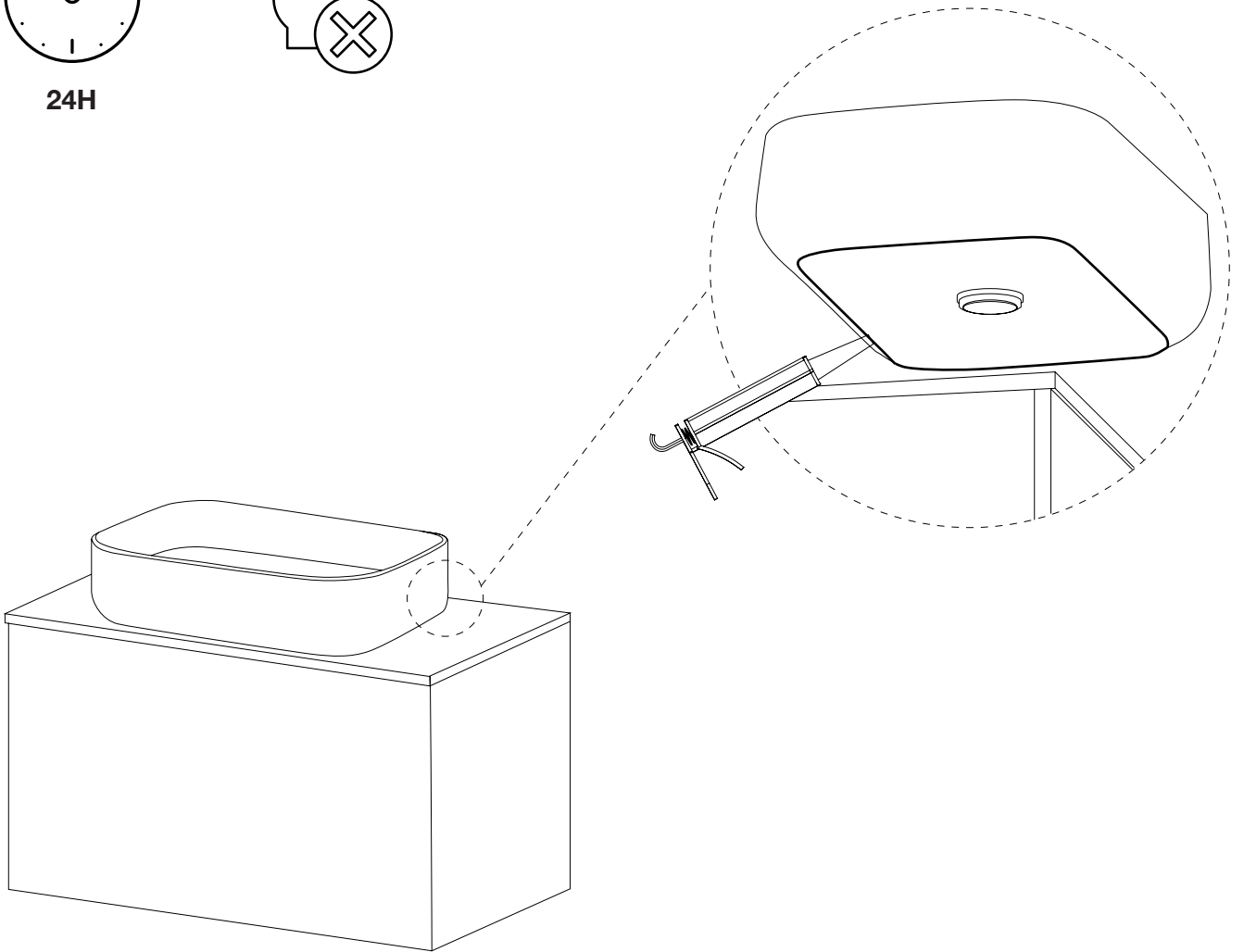

8.2. LAVABI CERAMICA INCASSO + Ghost, Nanco + Icaro + Block LAVABI CERAMICA INCASSO

La procedura è consigliata per tutti i lavabi in ceramica che si incassano nel mobile o sono a filo muro come: Nanco, Ghost, Icaro, e Block

The procedure is recommended for all ceramic sinks that are recessed into the cabinet or are flush-mounted, such as: Nanco, Ghost, Icaro, and Block.

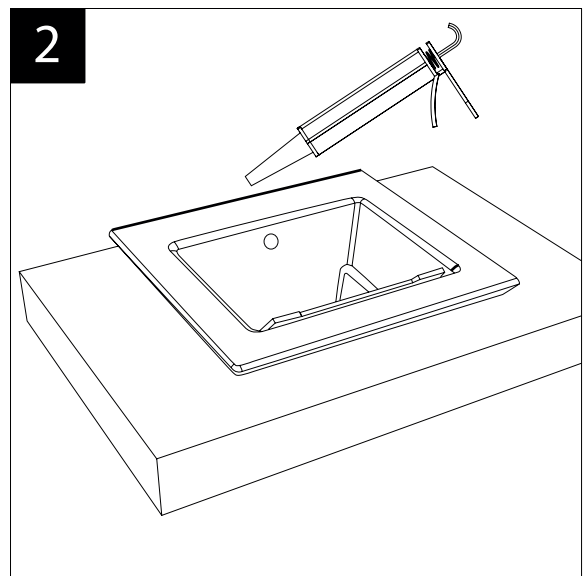
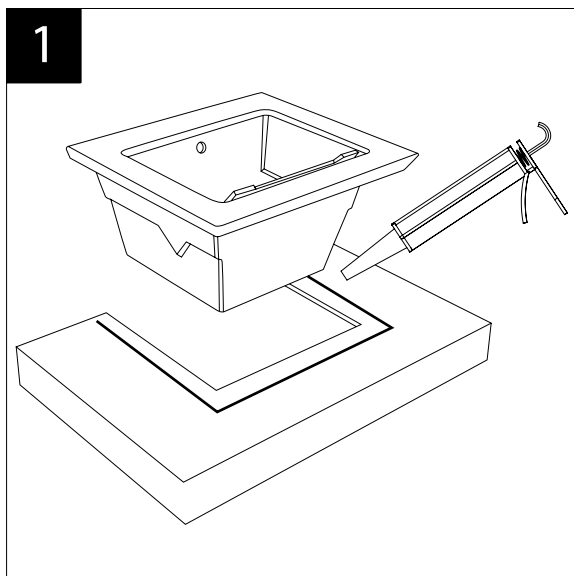

9. FISSAGGIO MENSOLONI MENSOLONI FIXING

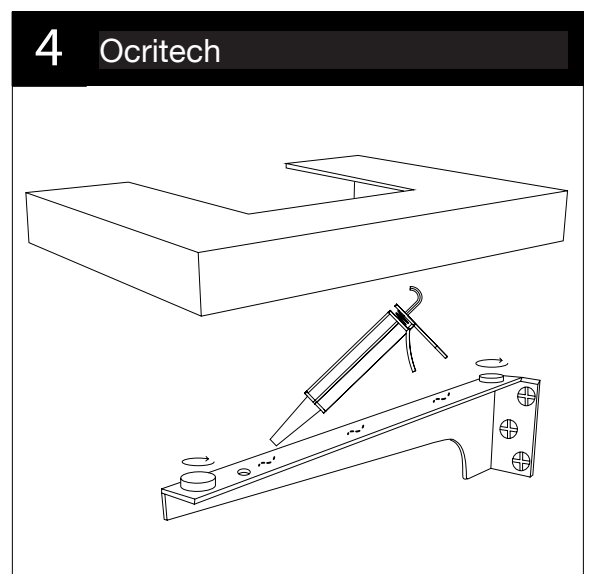
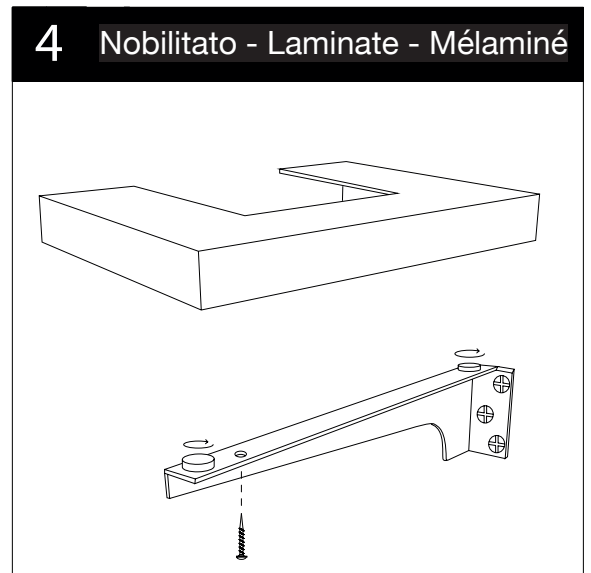
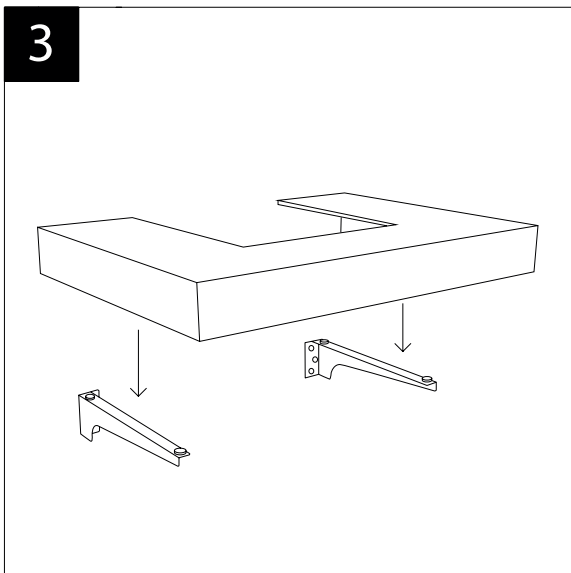
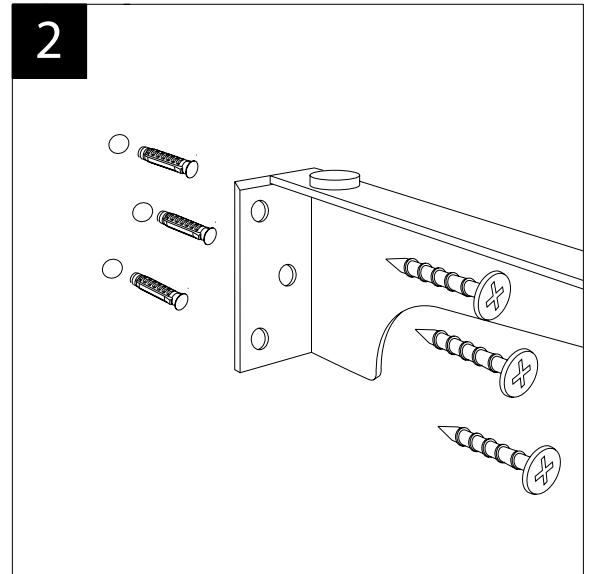
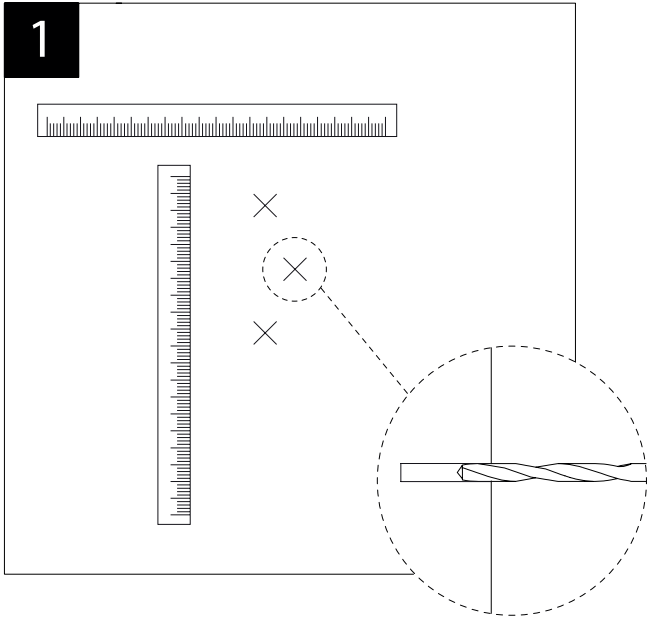

10. FISSASSIO DEI PIEDINI FIXING OF THE FEET

TIPO A
TIPE A

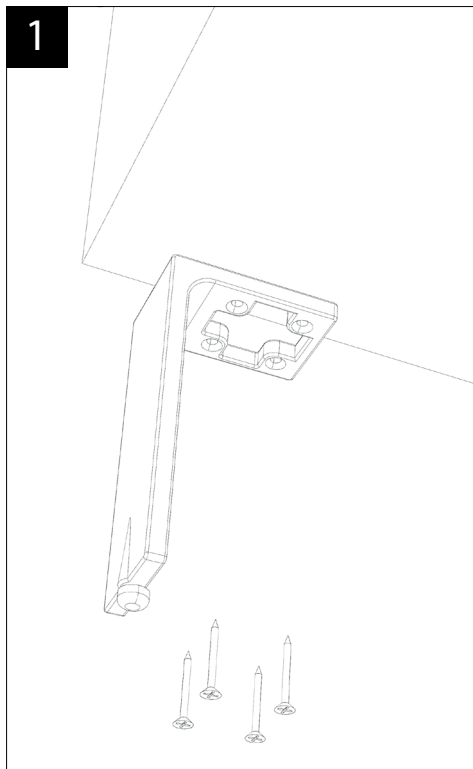

TIPO B
TIPE B

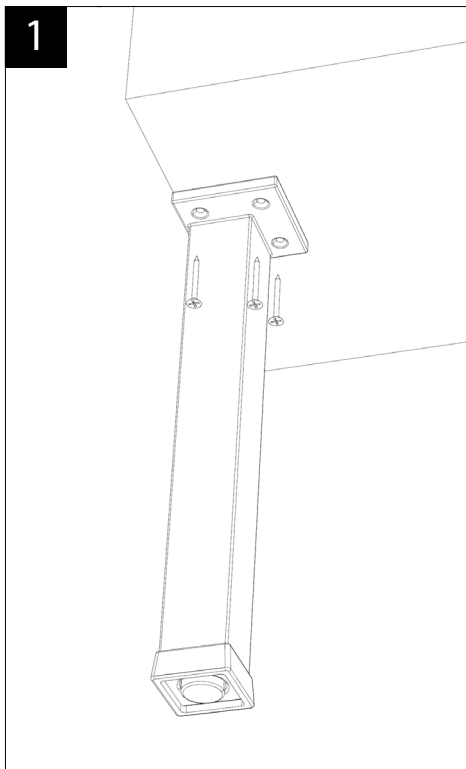

TIPO C
TIPE C

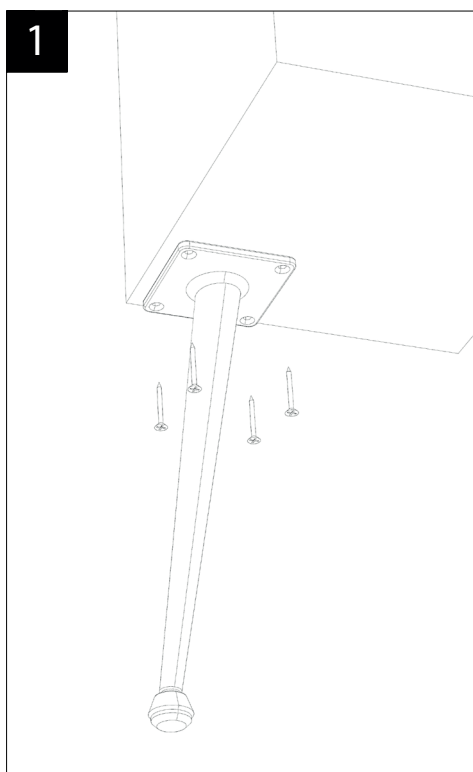

10. FISSASSIO DEI PIEDINI FIXING OF THE FEET

TIPO D
TIPE D

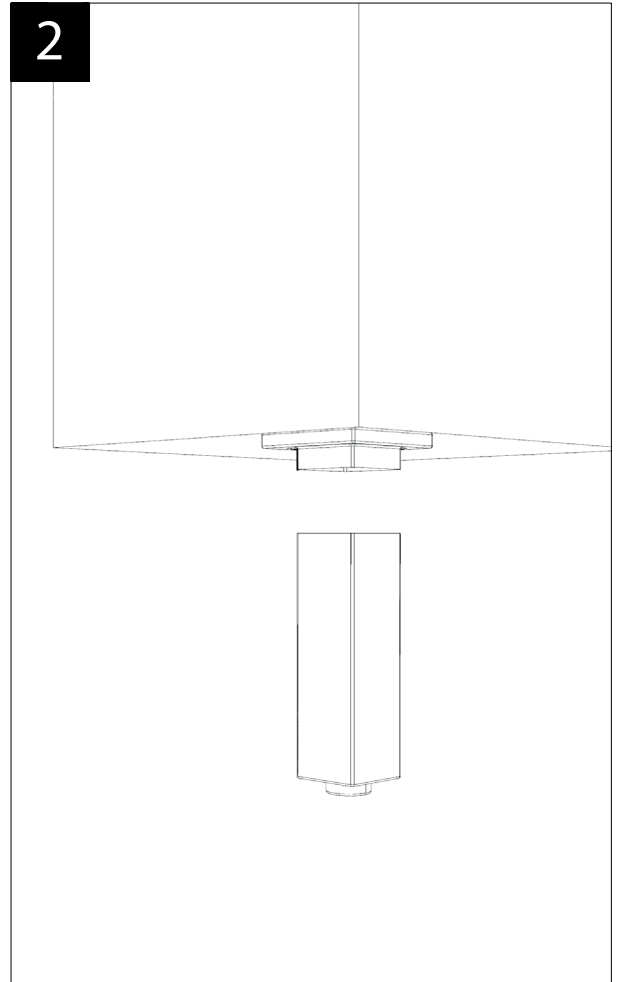
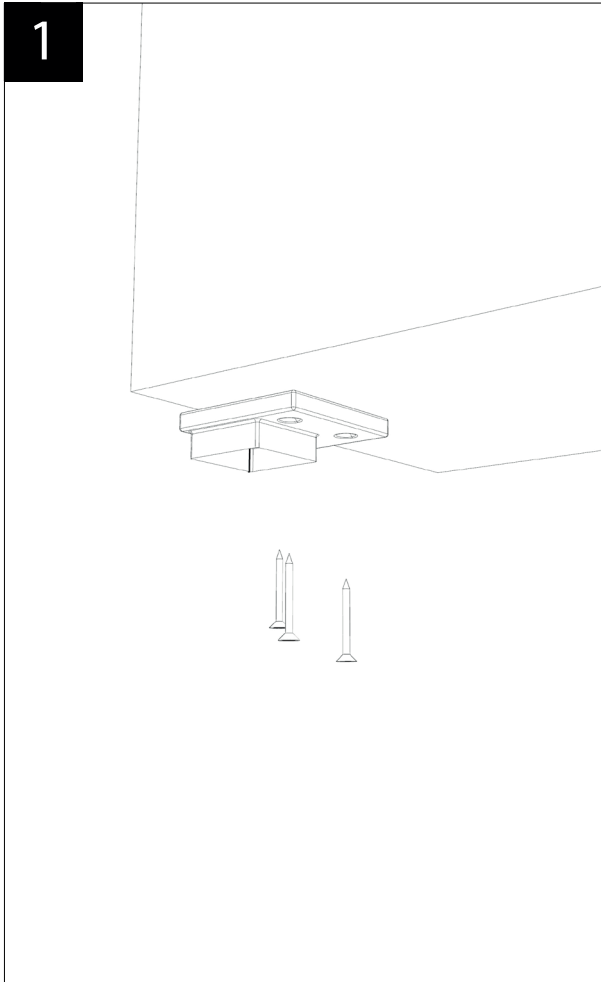

11. REGOLAZIONI E FISSAGGIO PENSILI ADJUSTMENTS AND HANGING CABINET FIXING

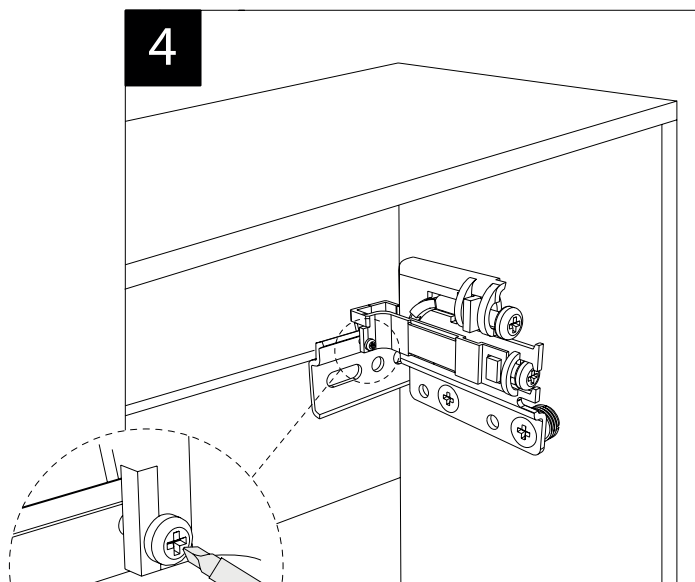
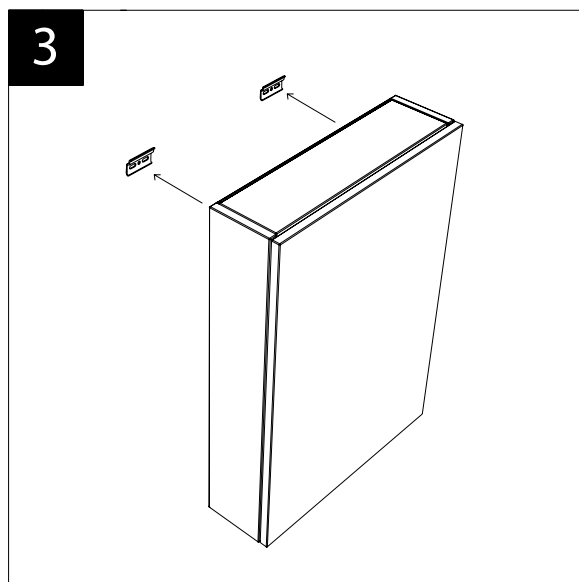
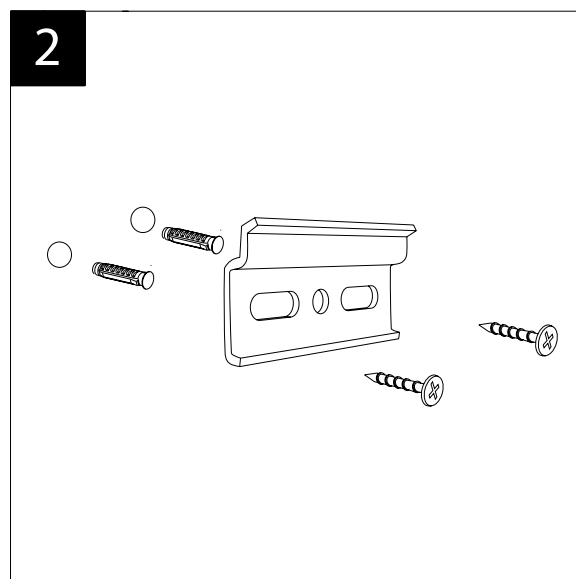
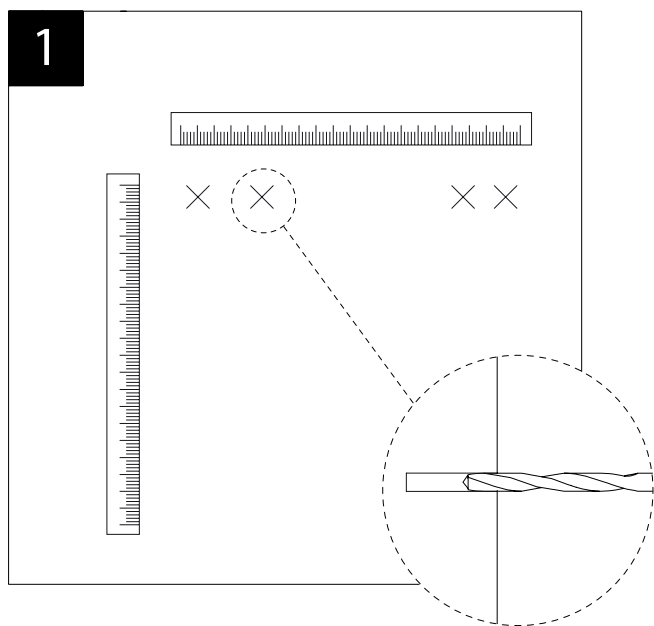

Antisgancio
Anti-unlocking
Anti-décrochage

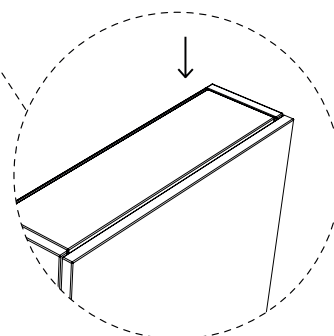

12. ATTACCAIA PENSILI A GIORNO HANGRES OPEN SHELVING

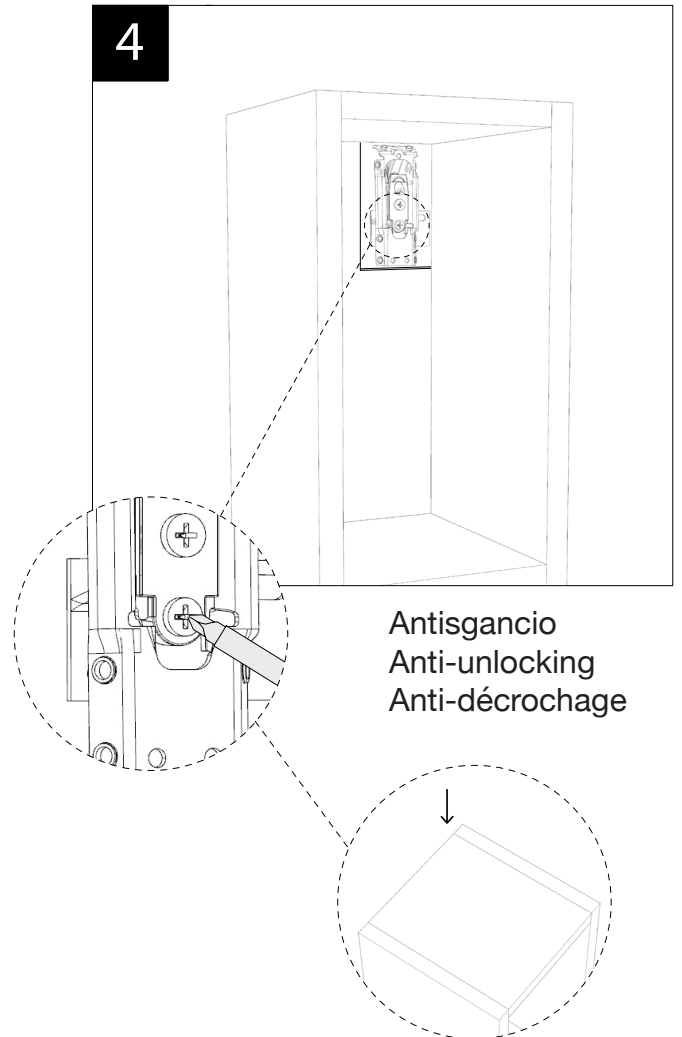
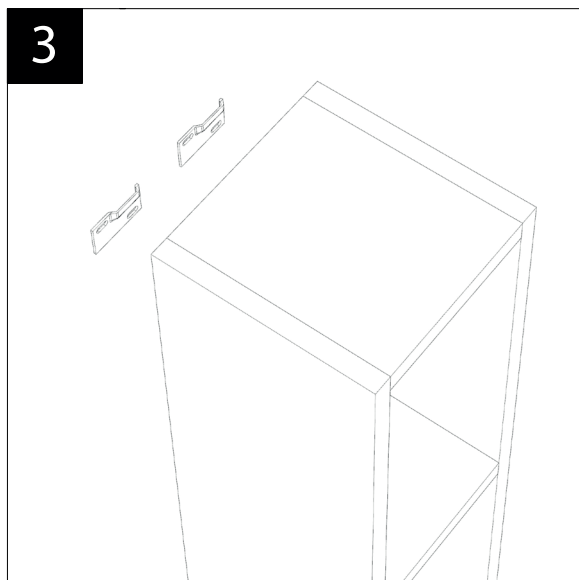
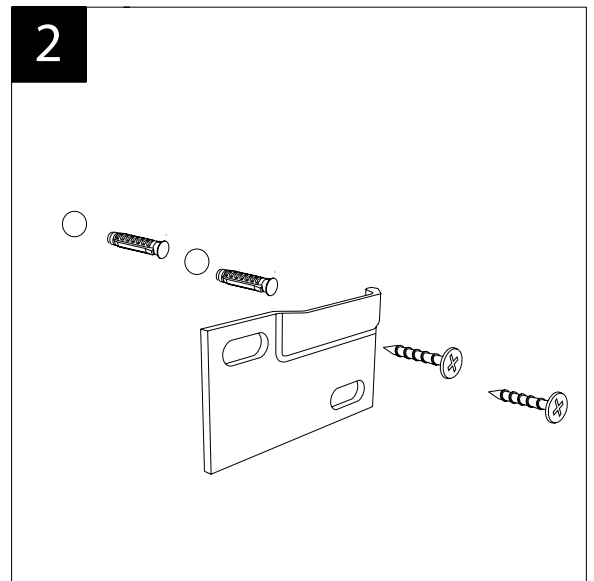
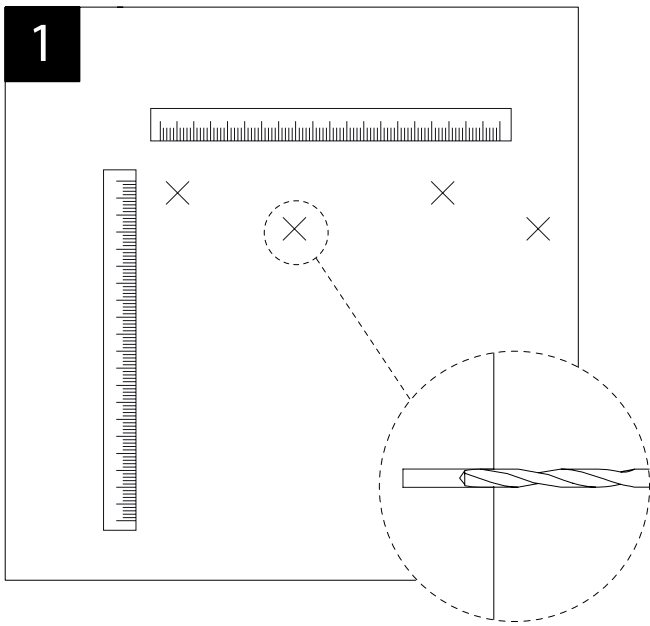

13. FISSAGGIO PENSILI SKEMA/ROAD MOUNTING WALL CABINETS SKEMA.

Misurare la distanza dei fori e segnarli sul muro, effettuare il foro e inserire il fisher adatta alla vostra parete e inserire direttamente le viti. Eseguire poi l'aggancio come in figura.

Measure the hole spacing and mark it on the wall, drill the hole, insert the appropriate wall plug, and screw in the screws directly. Then, perform the attachment as shown in the diagram.

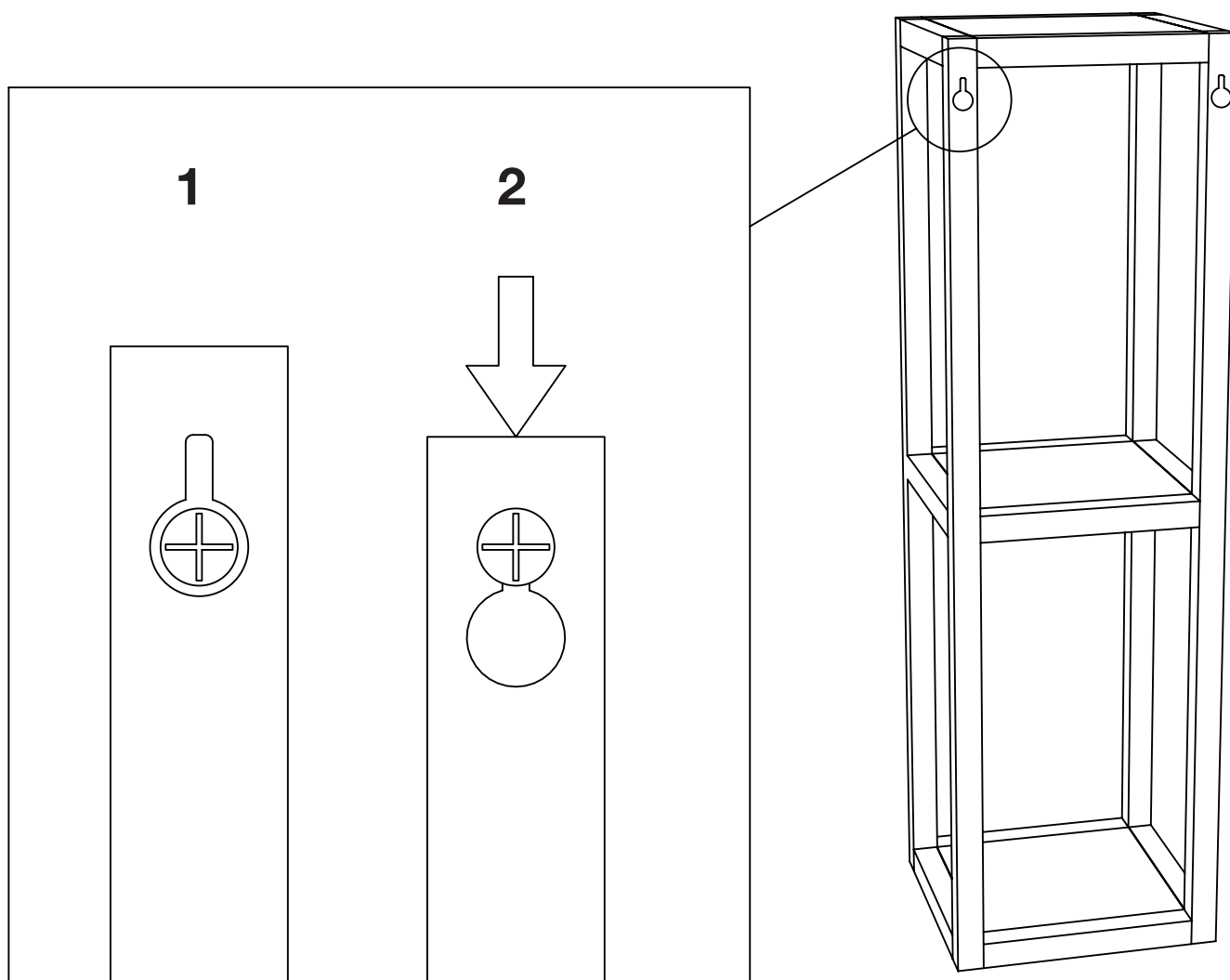

13. FISSAGGIO SKEMA/ROAD ROAD FIXING

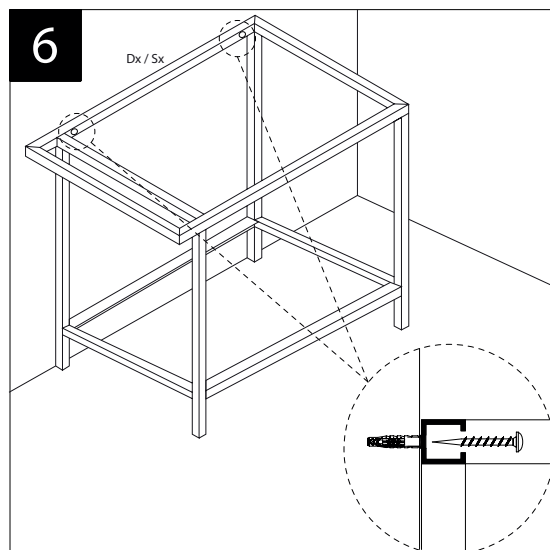
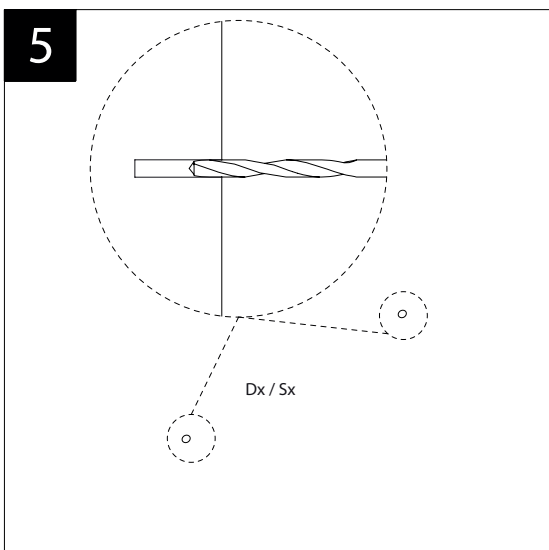
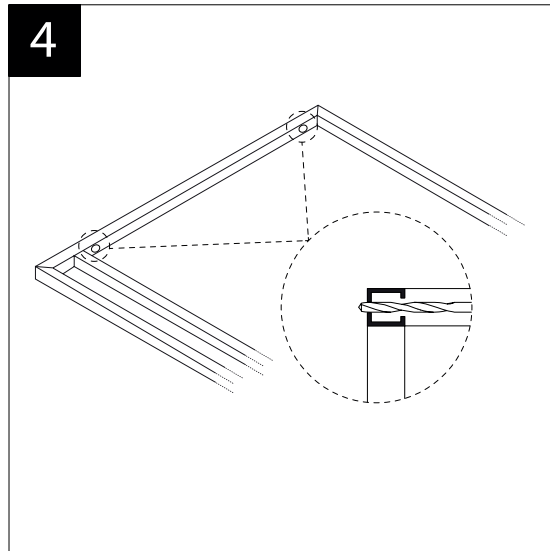
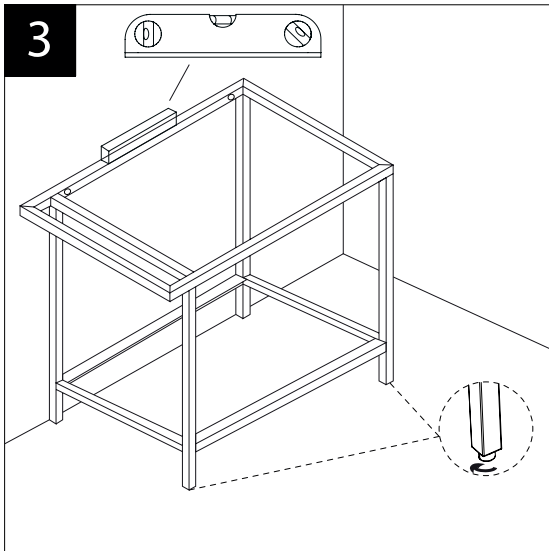
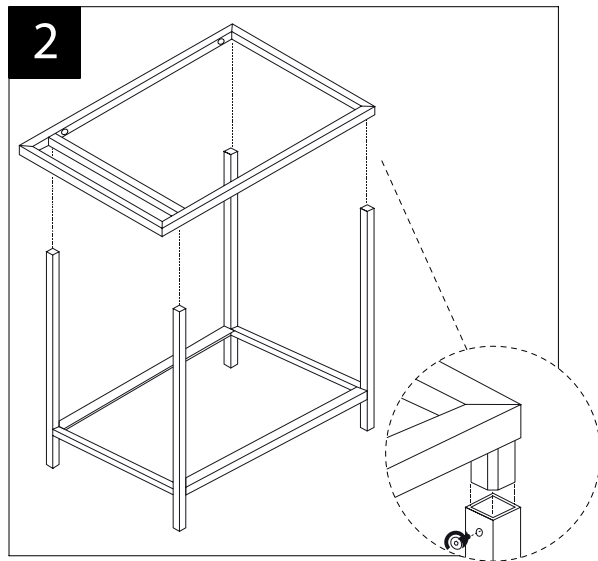
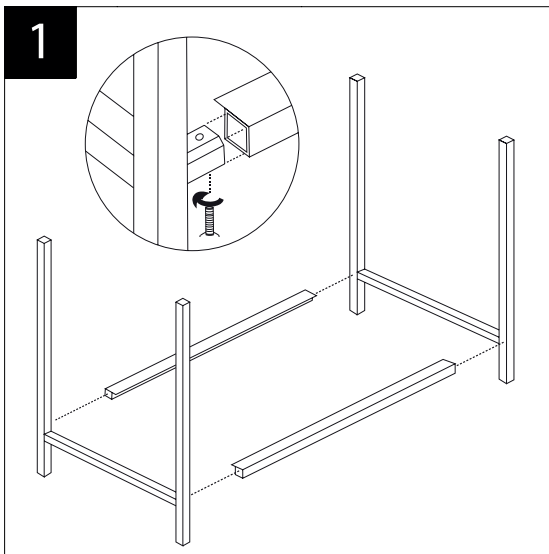



24H

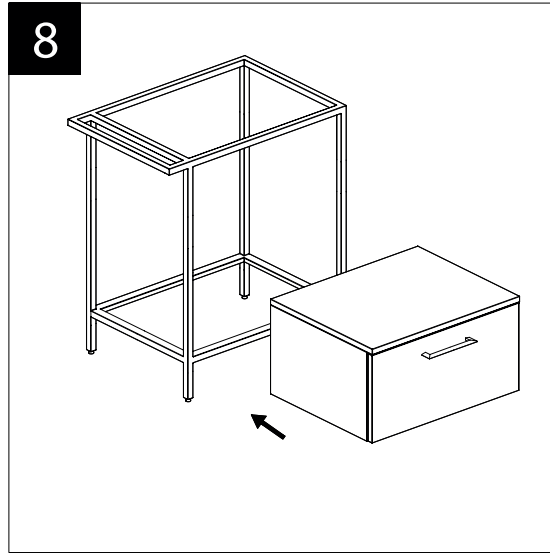
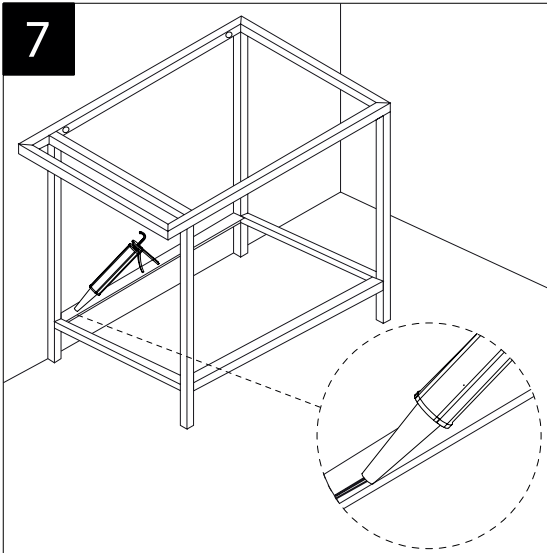

24H

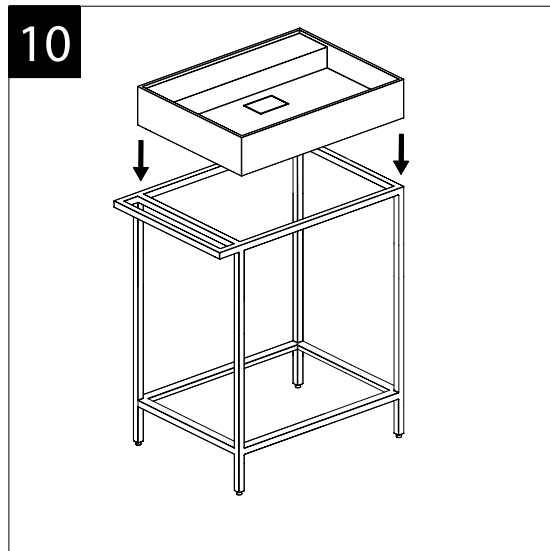
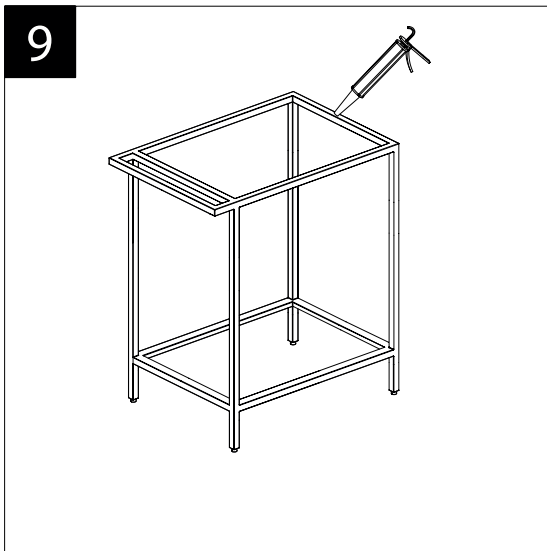

REGOLAZIONI

ITA

CLICCA SUL TESTO PER
VEDERE I RELATIVI VIDEO

ENG

CLICK ON THE TEXT TO
SEE THE RELATED VIDEOS.

FR

CLIQUEZ SUR LE TEXTE
POUR VOIR LES VIDÉOS
ASSOCIÉES.

REGOLAZIONI CERNIERE
HINGE ADJUSTMENTS.



REGOLAZIONI CASSETTO
DRAWER ADJUSTMENTS.

14. CASSETTI
DRAWERS

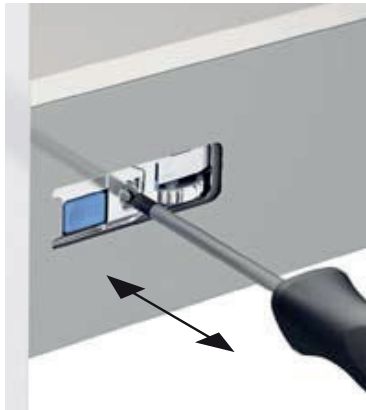

Regolazione laterale
Lateral adjustment

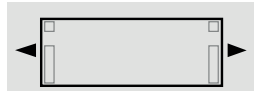

Vista frontale
Front view



Regolazione dell'altezza
+/-2 mm
*Height adjustment
+/-2 mm*



Regolazione dell'inclinazione
tramite la
ringhierina

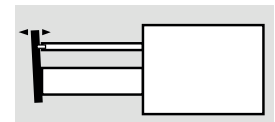

Vista laterale
Side view



Montaggio del
frontale
Frontal assembly



Smontaggio senza
utensili
*Tool-free
disassembly*



Montaggio cassetto
facilitato: basta
appoggiarlo sulle
guide e inserirlo
*Easy drawer
assembly: simply
place it on the
guides and insert it.*

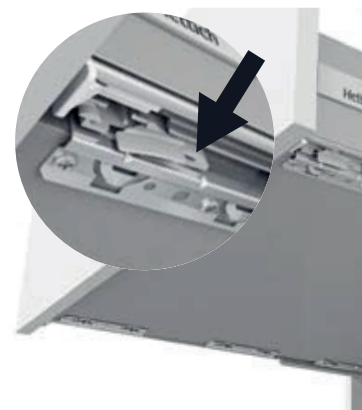

Smontaggio
facilitato: premere
le linguette sotto il
cassetto e sfilarlo
dalle guide
*Easy disassembly:
press the tabs
underneath the
drawer and slide it
off the rails.*

LAUNDRY SHELF

15. LAUNDRY SHELF PONTE
LAUNDRY SHELF BRIDG

15.1 LAUNDRY SHELF - PONTE TIPO 2
LAUNDRY SHELF - BRIDG TIPE 2

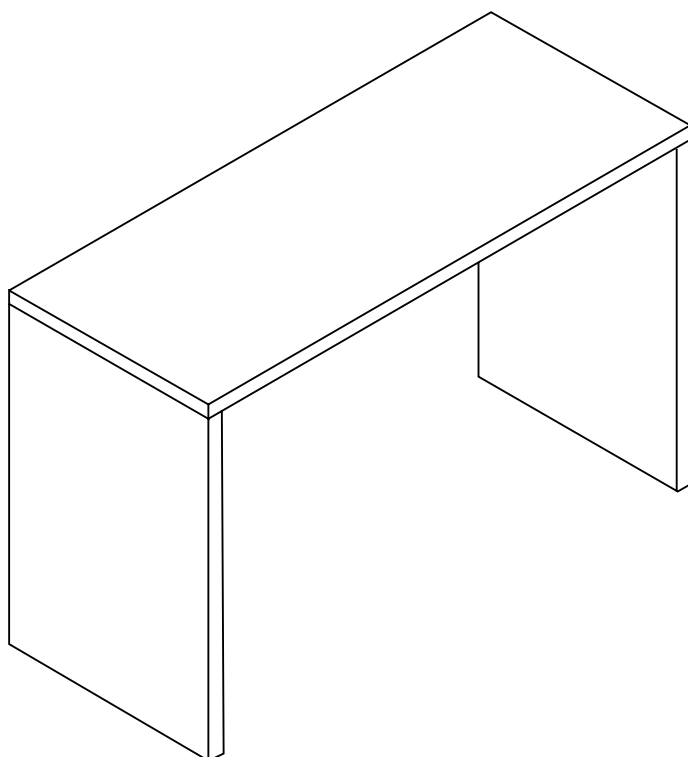

x1

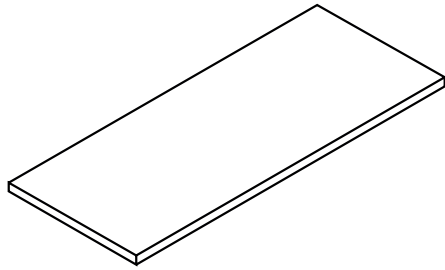

x2

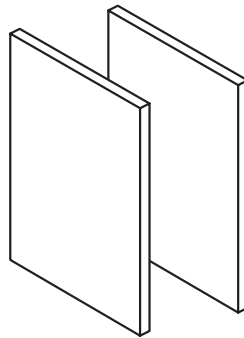

X6



X6

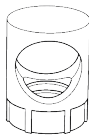

X6



X8



X2

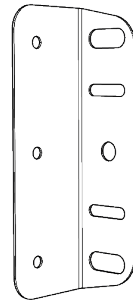

X4



X2



X4

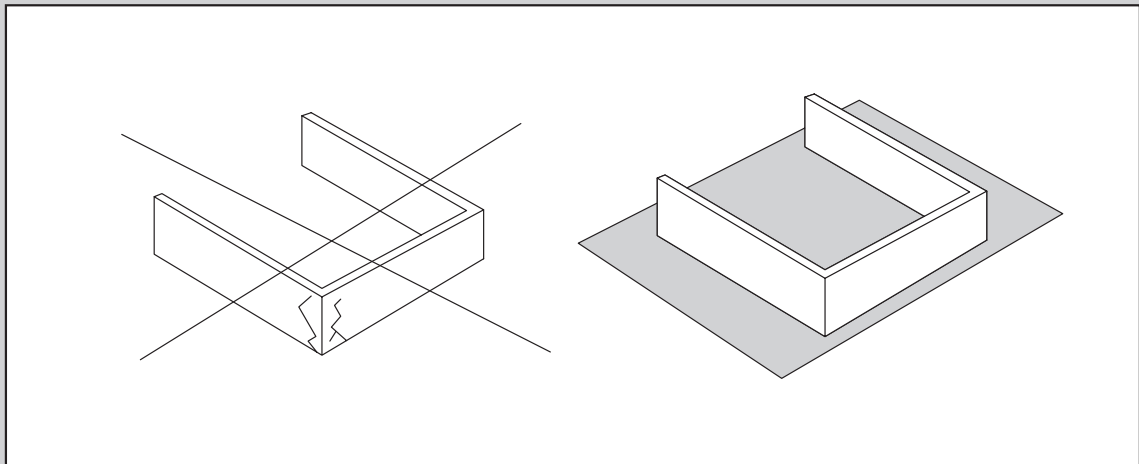
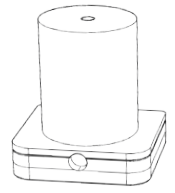

x6

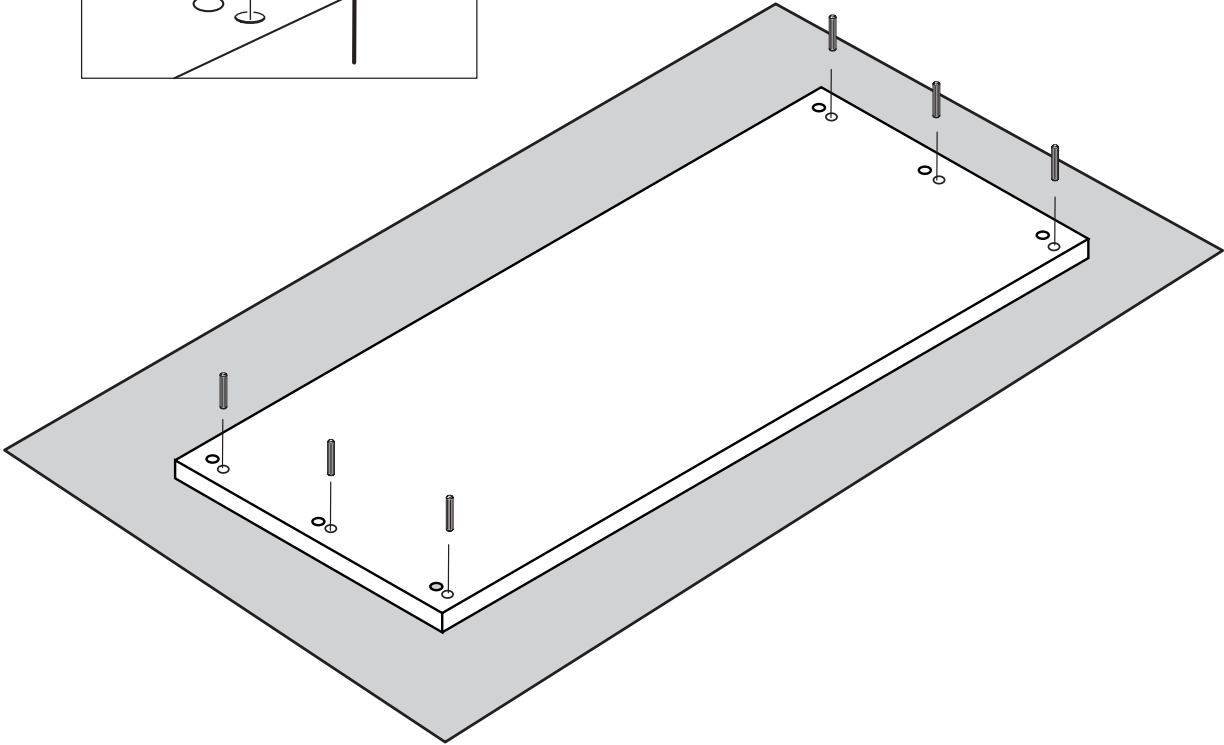
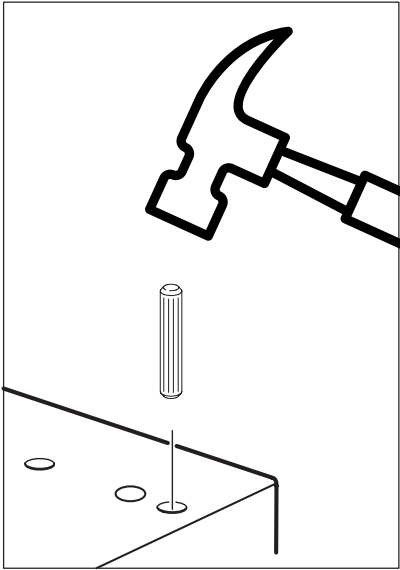

X6

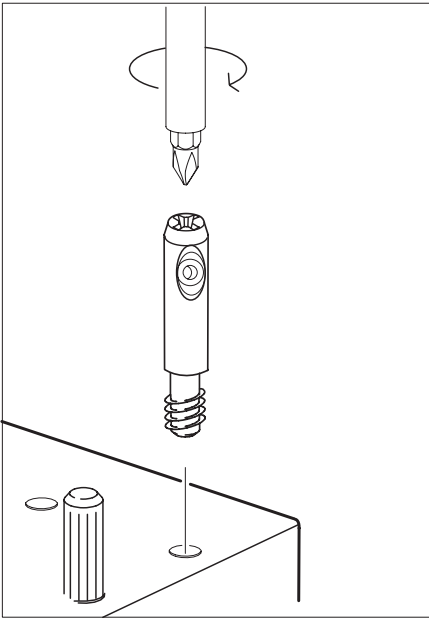

IT

Orientare il foro verso il pannello da agganciare nel passaggio successivo.

ENG

Orient the hole towards the panel to be attached in the next step.

FR

Orienter le trou vers le panneau à fixer dans l'étape suivante.

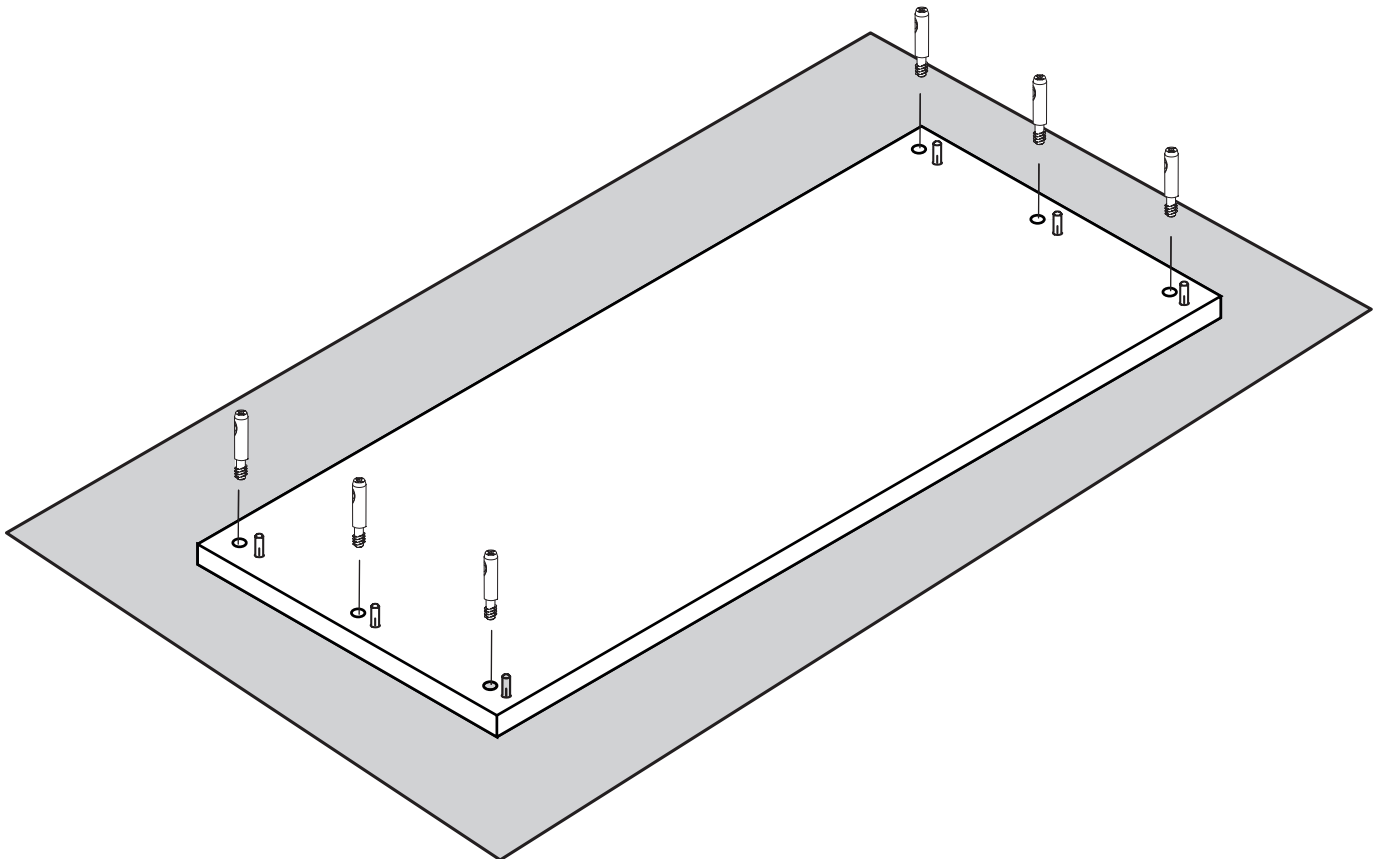

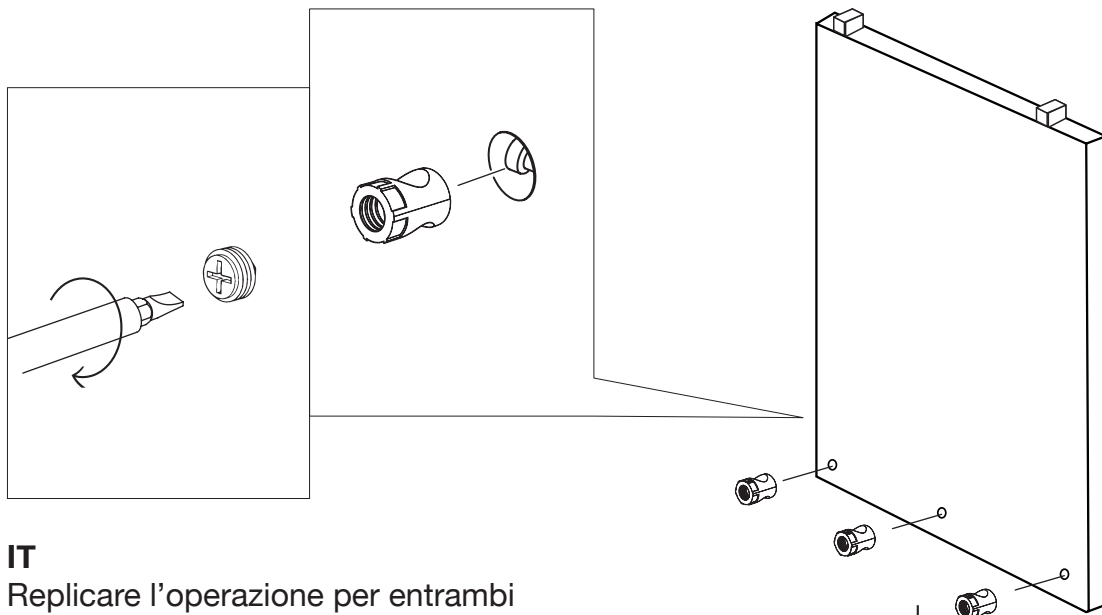

IT

Replicare l'operazione per entrambi i laterali del ponte.

ENG

Repeat the operation for both sides of the bridge.

FR

Répéter l'opération pour les deux côtés du pont.

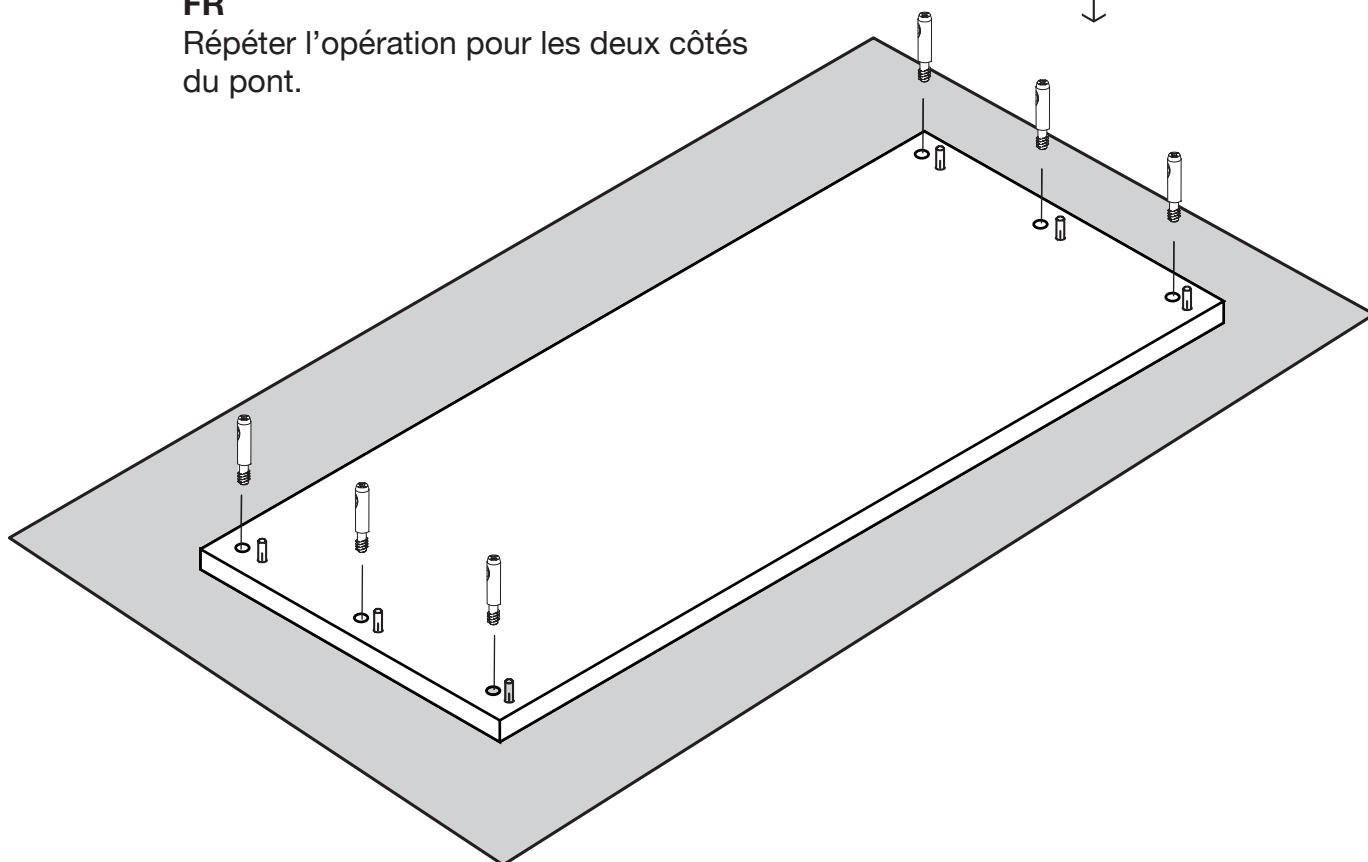

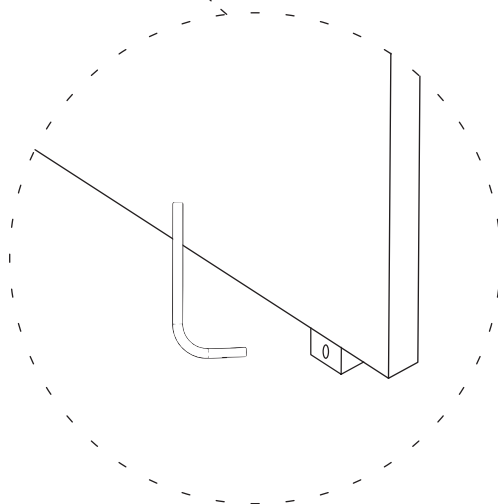
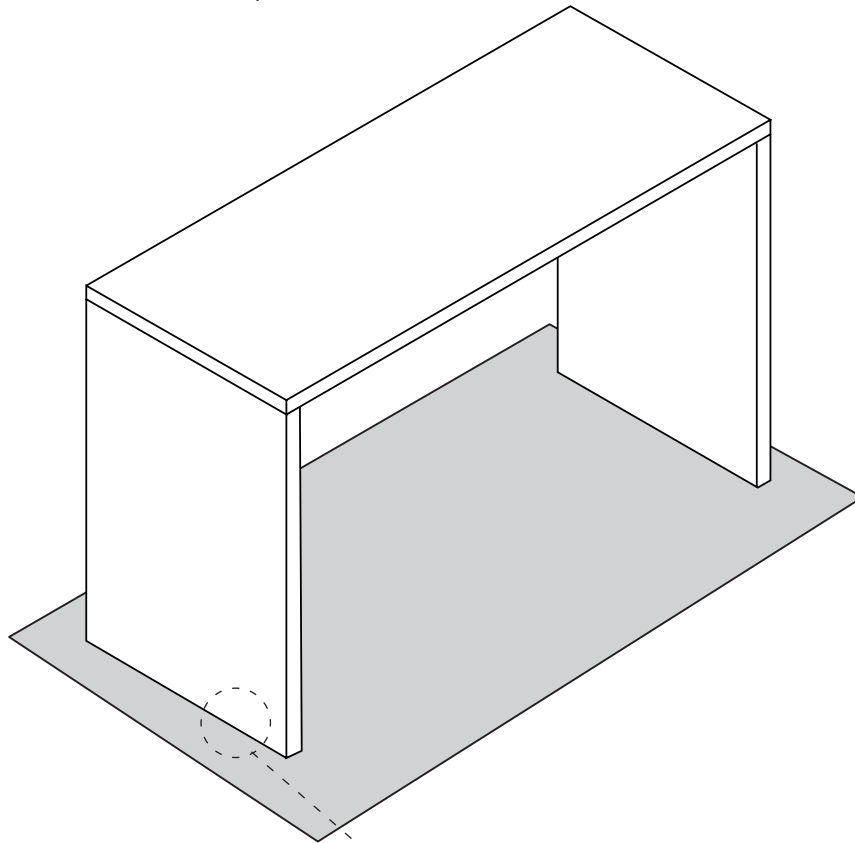
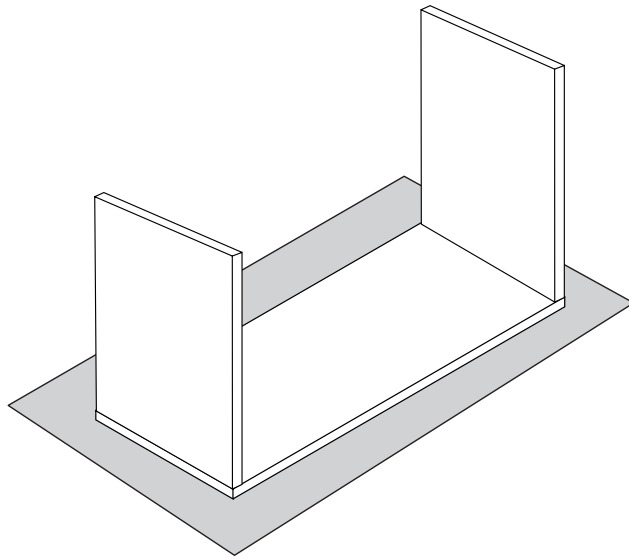

IT
Regolazione del piedino

ENG
Adjustment of the foot

FR
Réglage du pied

18.2 LAUNDRY SHELF - PONTE TIPO 2
LAUNDRY SHELF - BRIDG TIPE 2

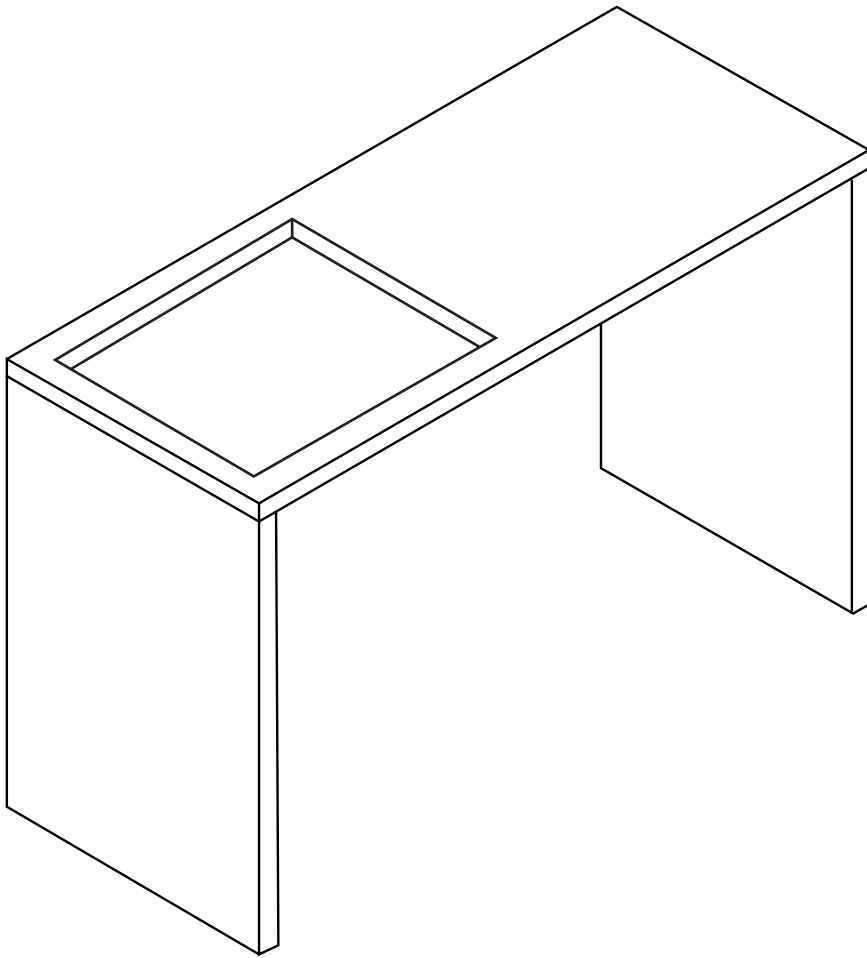

x1

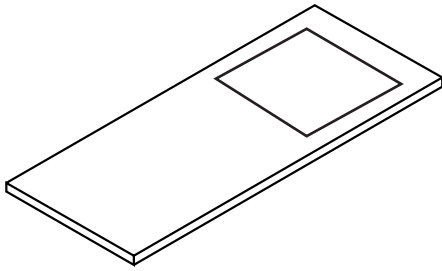

x2

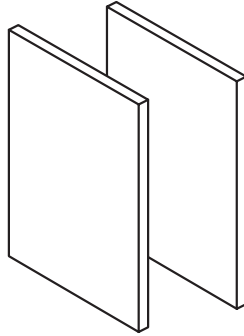

X6



X6

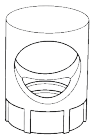

X6



X8



X2

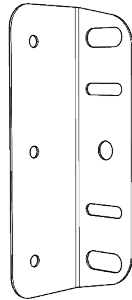

X4



X2



X4

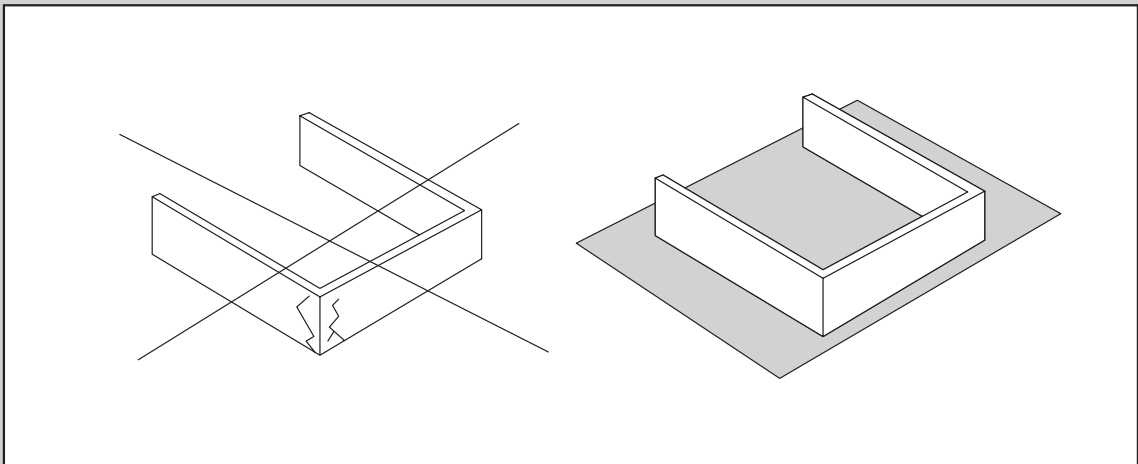
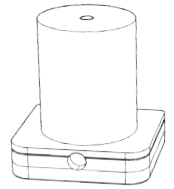

x6

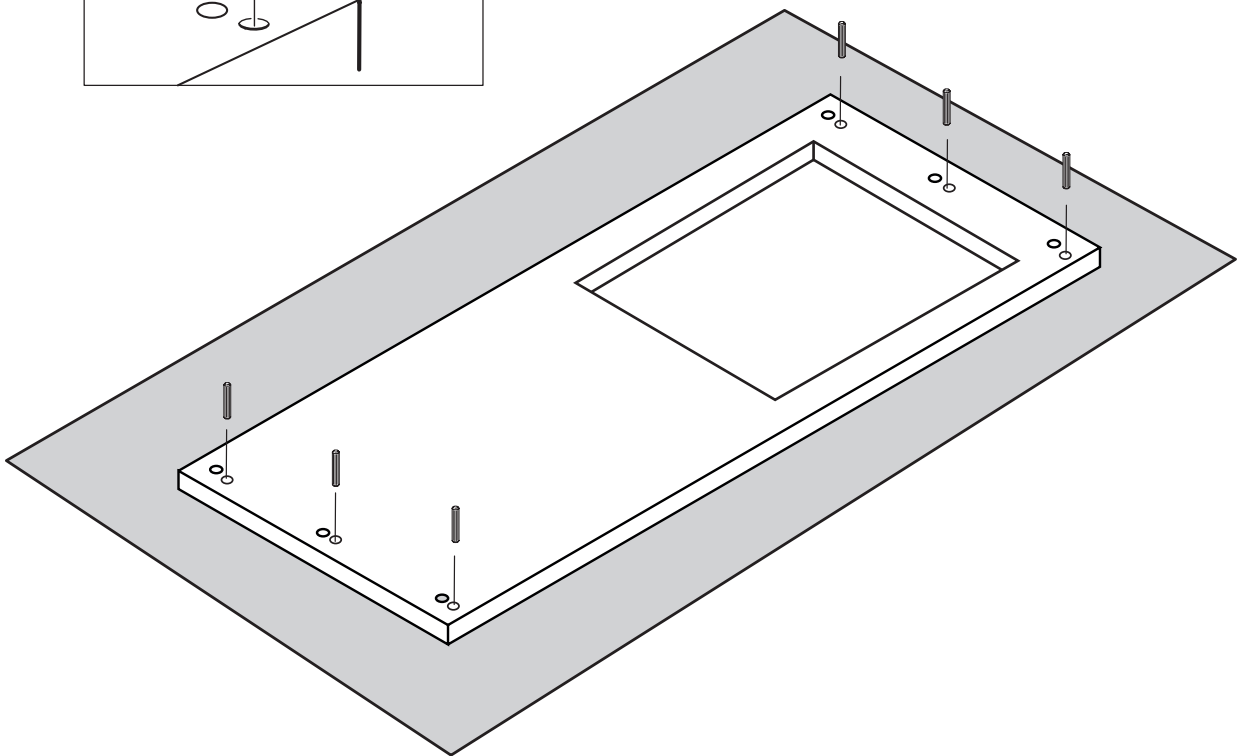
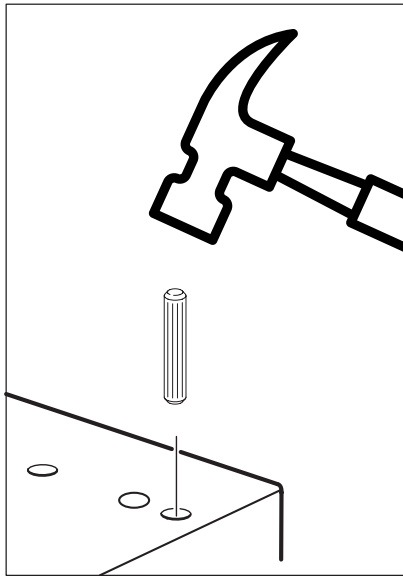

X6

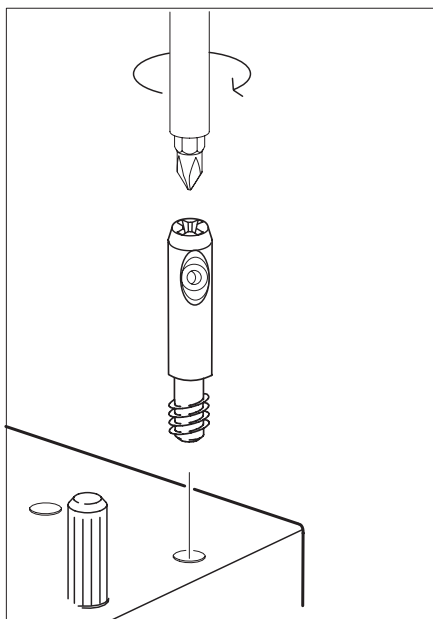

IT

Orientare il foro verso il pannello da agganciare nel passaggio successivo.

ENG

Orient the hole towards the panel to be attached in the next step.

FR

Orienter le trou vers le panneau à fixer dans l'étape suivante.

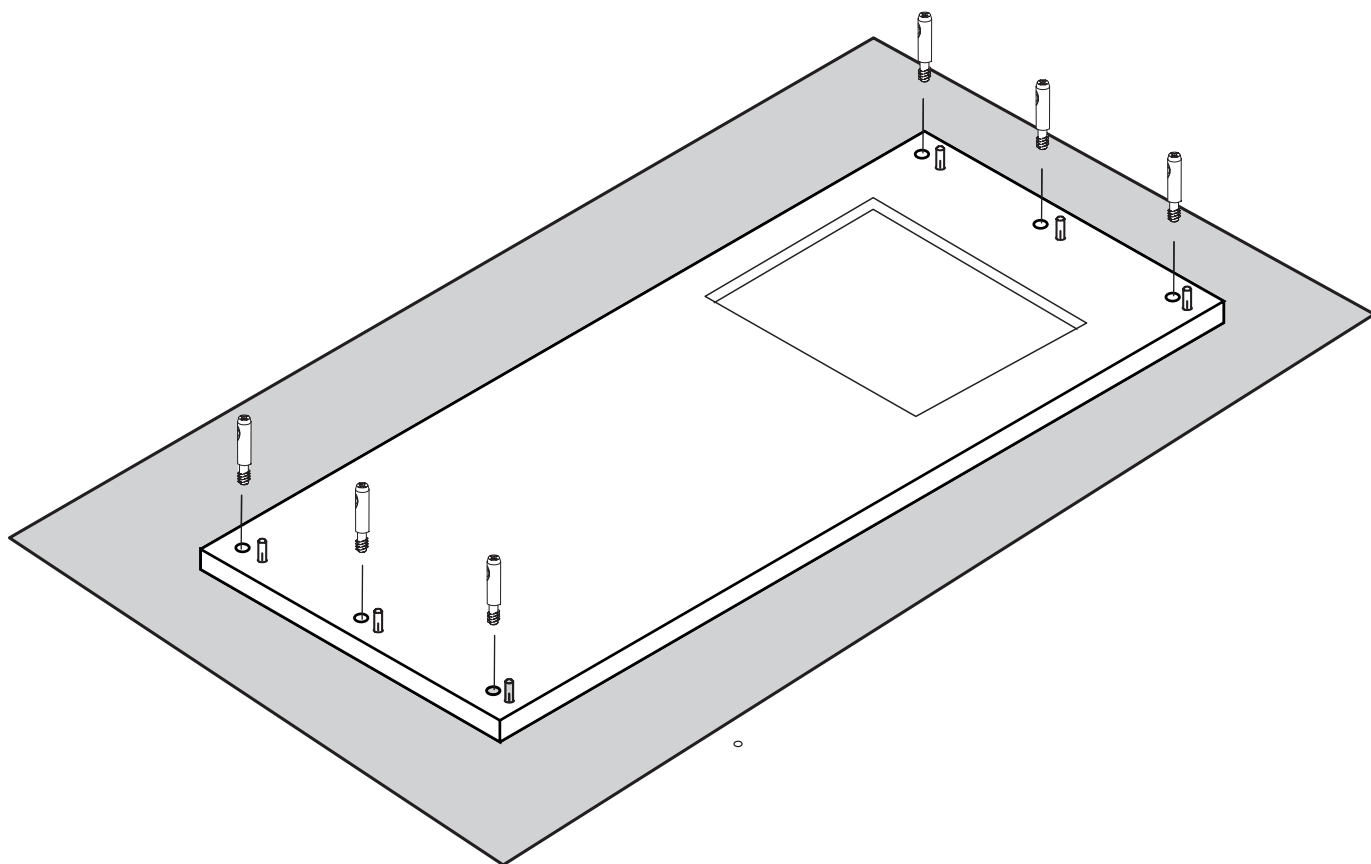

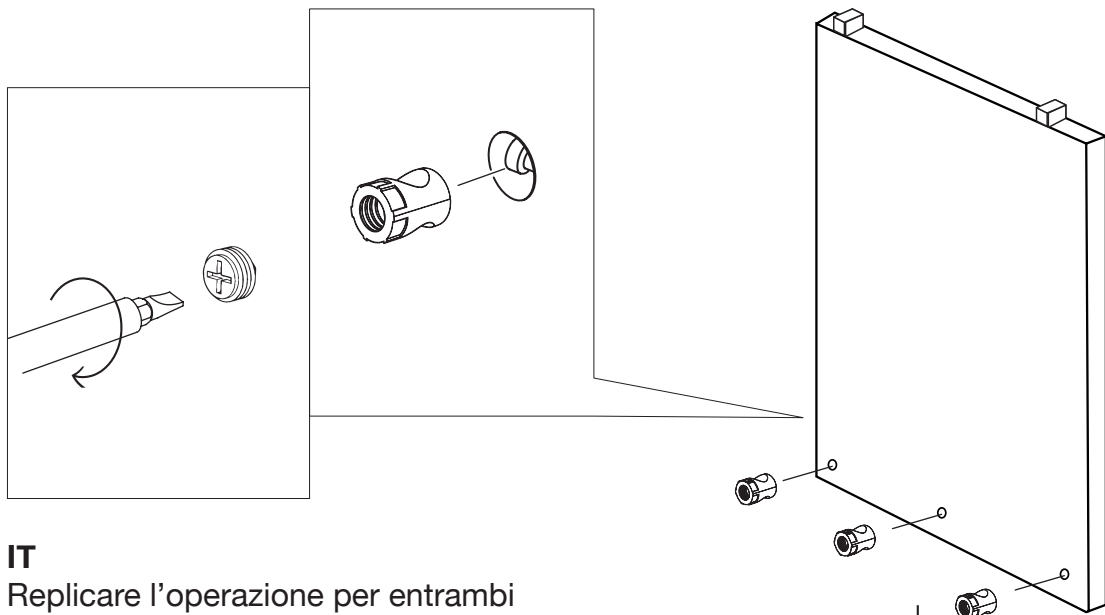

IT
Replicare l'operazione per entrambi i laterali del ponte.

ENG
Repeat the operation for both sides of the bridge.

FR
Répéter l'opération pour les deux côtés du pont.

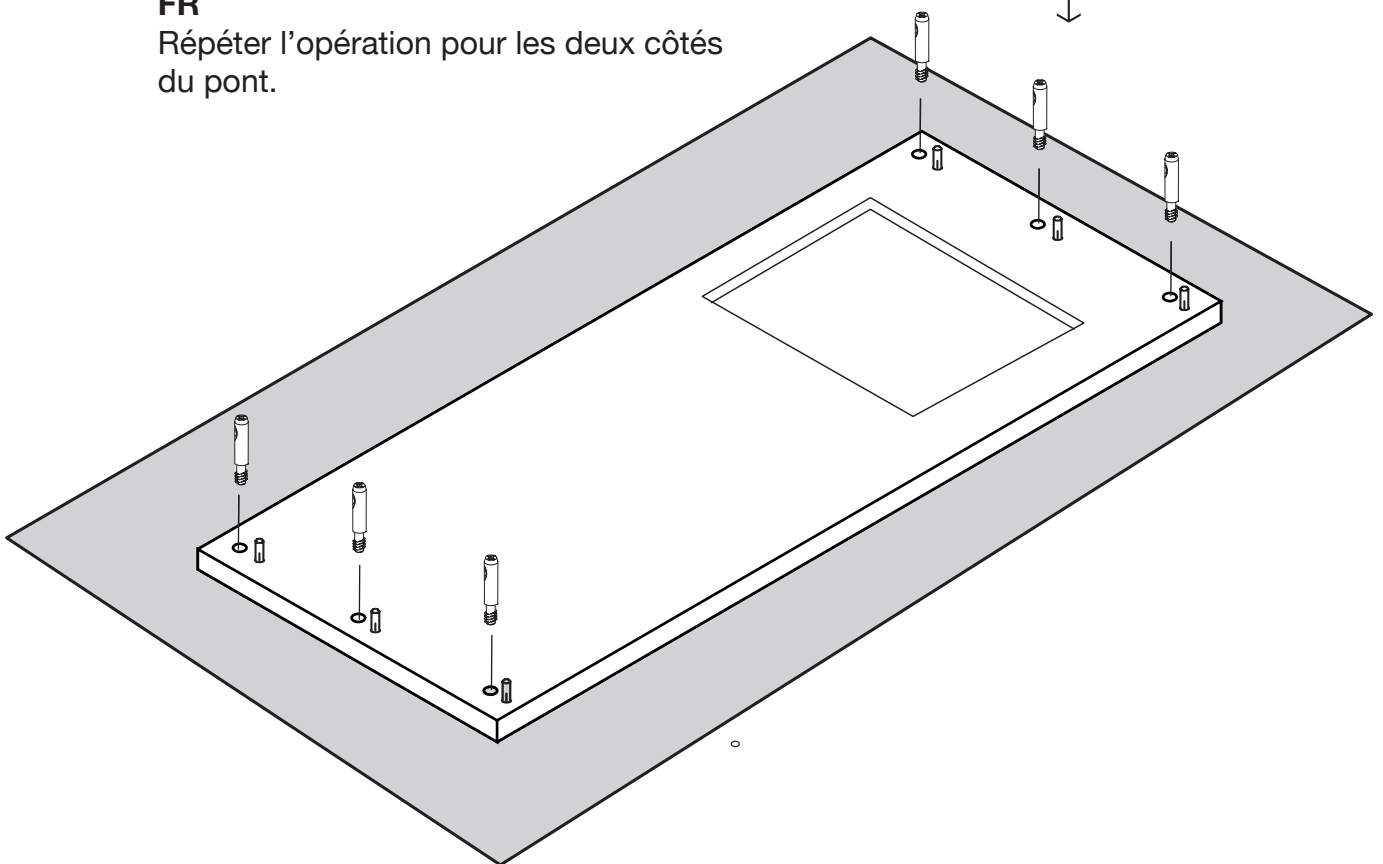

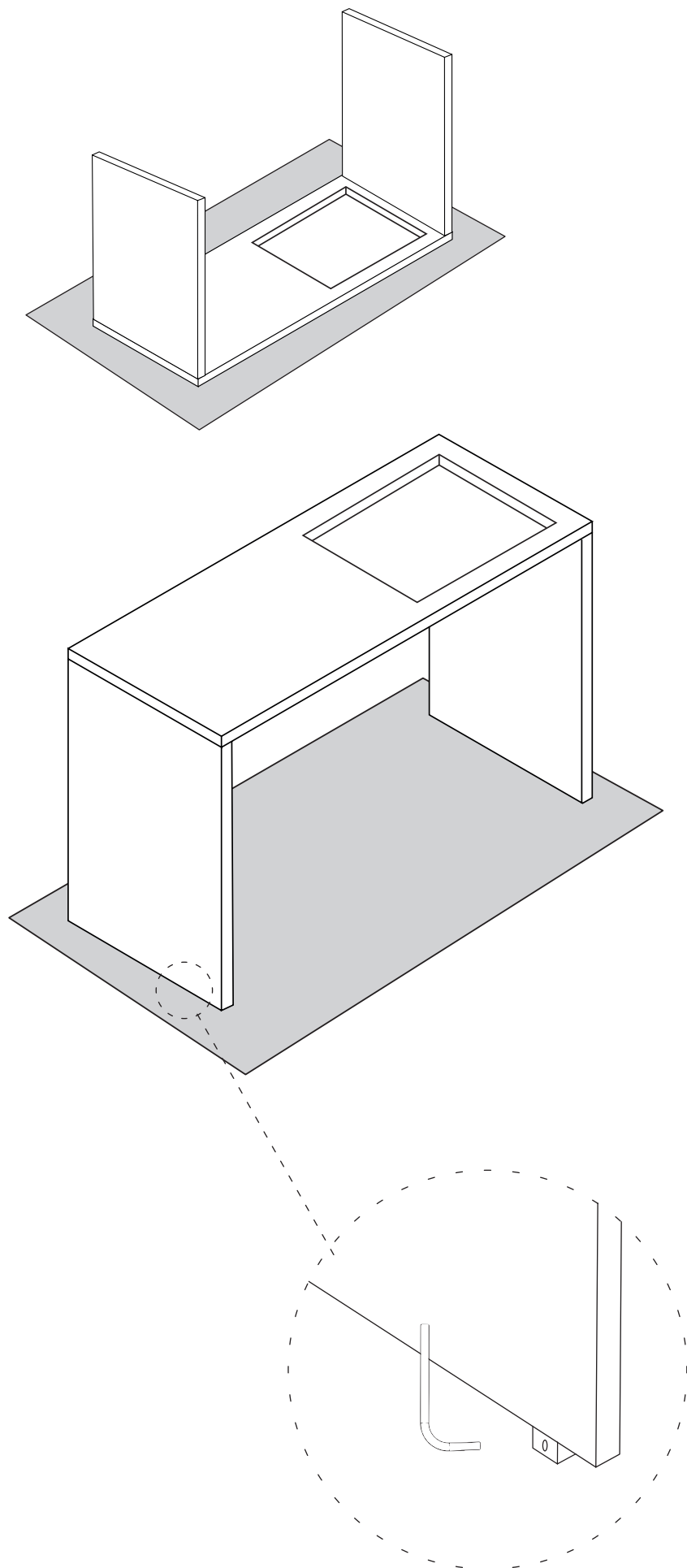

IT
Regolazione del piedino

ENG
Adjustment of the foot

FR
Réglage du pied

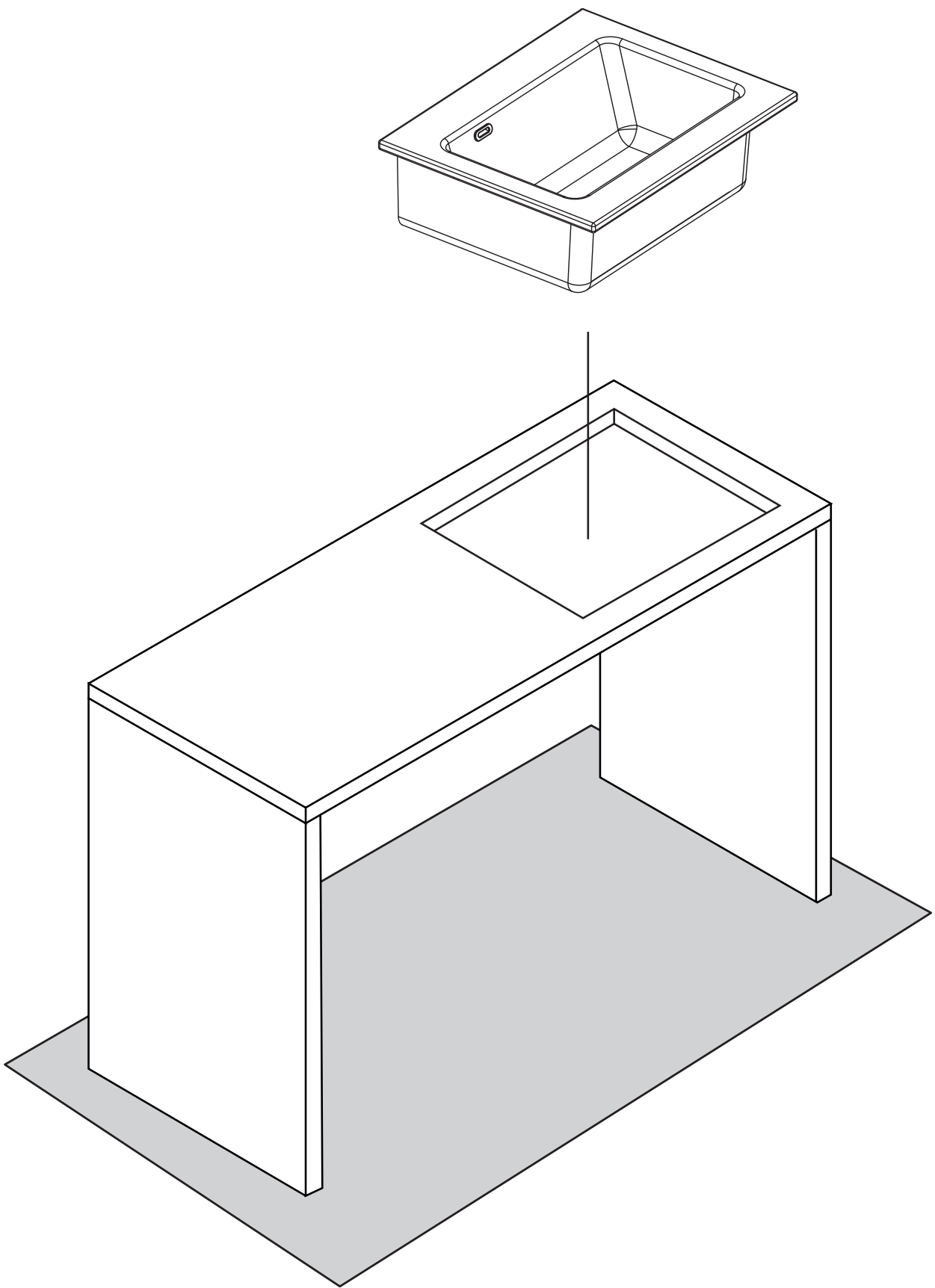

IT

Tagliare con il seghetto la parte del foro che poggia al muro.

ENG

Cut with a hacksaw the part of the hole that rests against the wall.

FR

Couper avec une scie la partie du trou qui repose contre le mur.

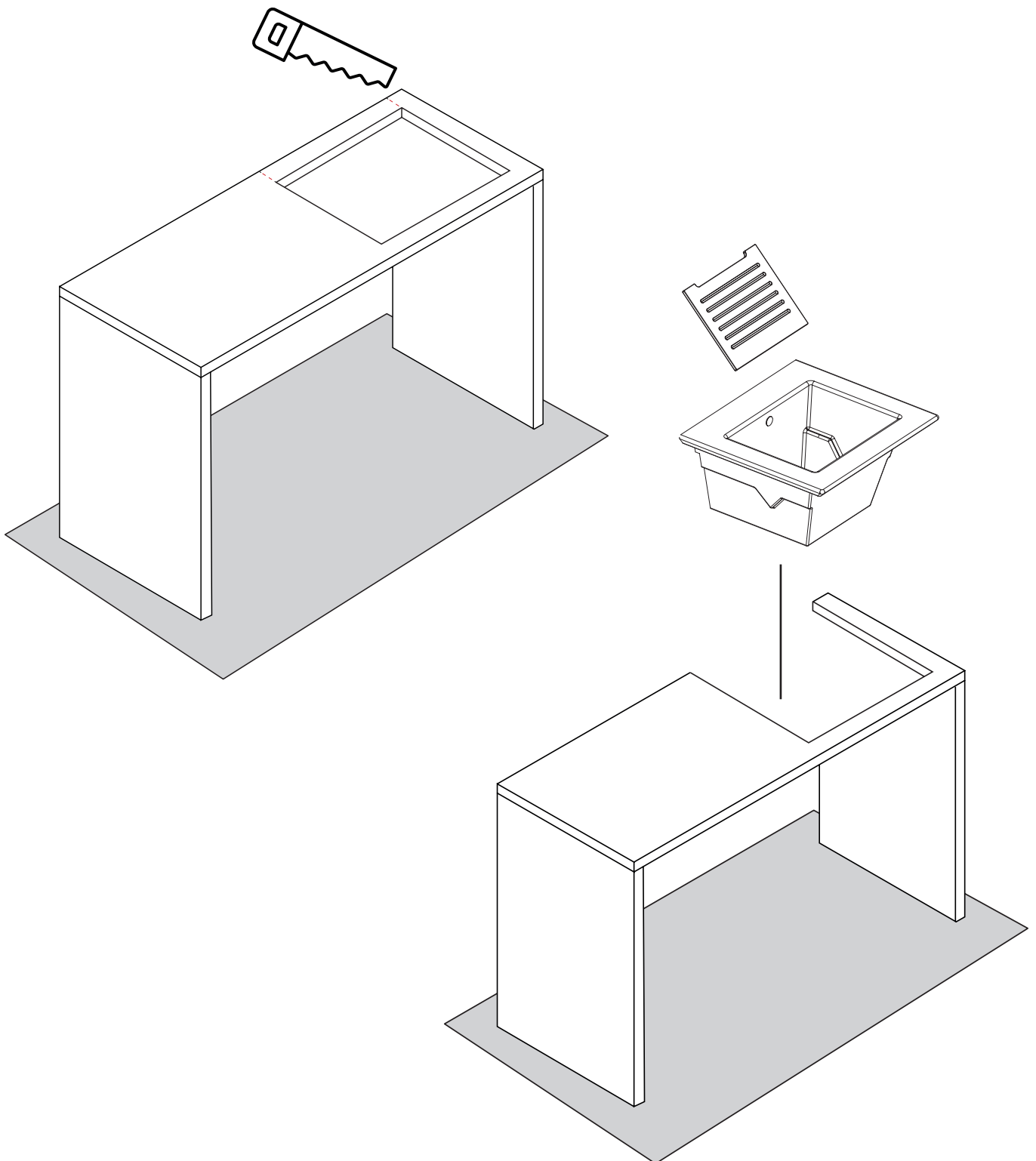

15.2 LAUNDRY SHELF - COLONNA H198/h141
LAUNDRY SHELF - COLONNA

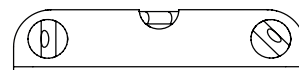
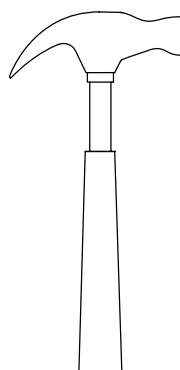
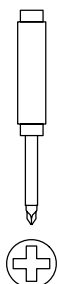
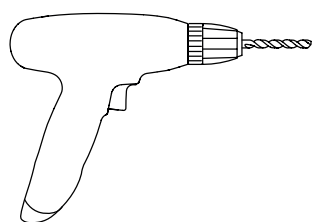
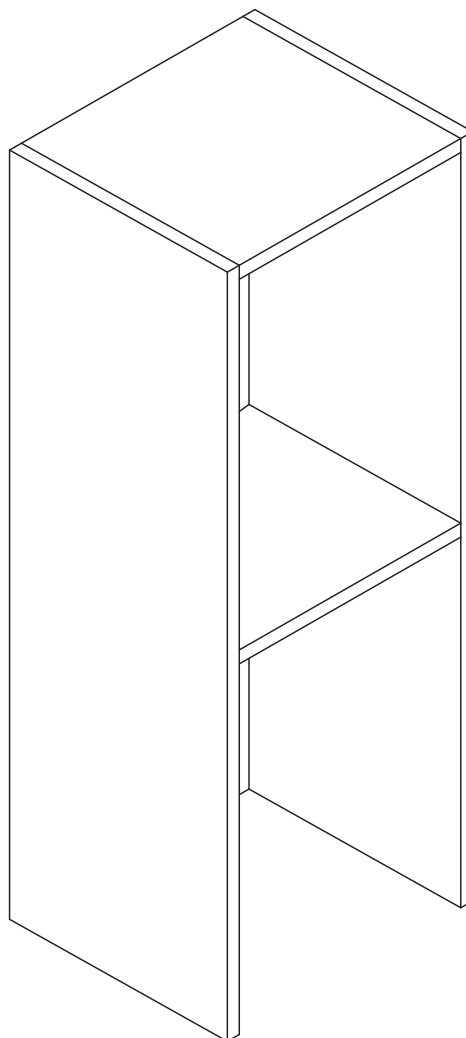
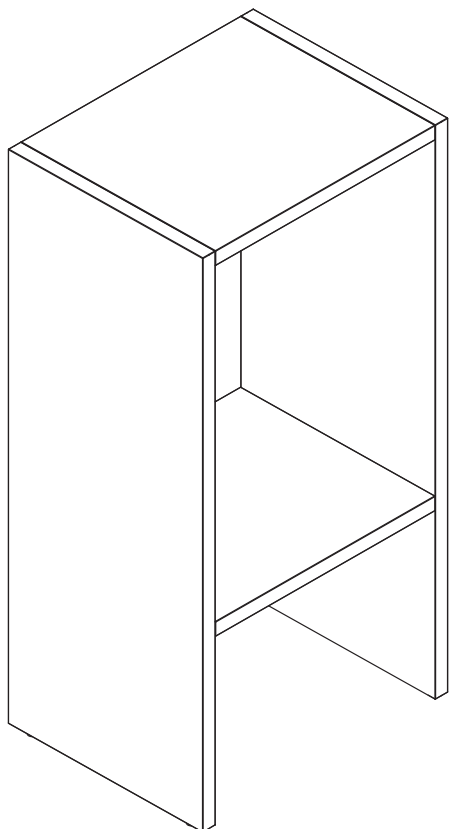

x2

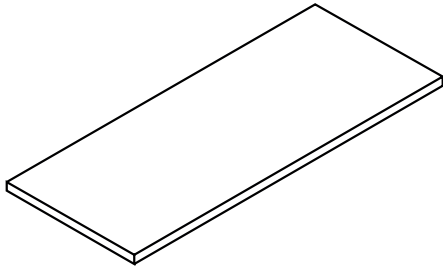

x2

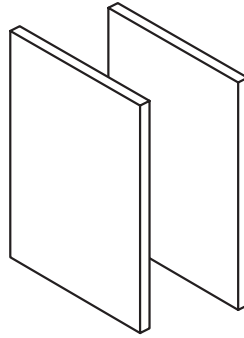

x2

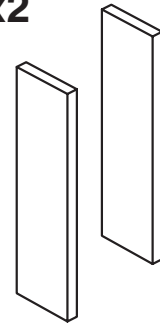

X4

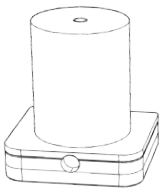

X12



X4



X12

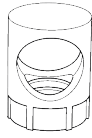

X12



X4

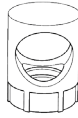

X4



X16

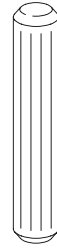

X8



X1

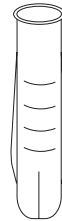

X1



X6



X4

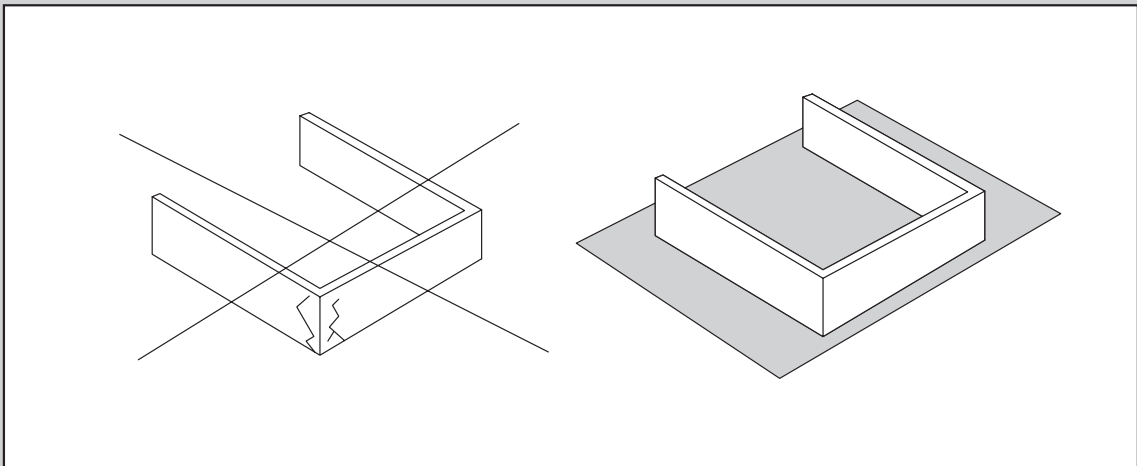

x8

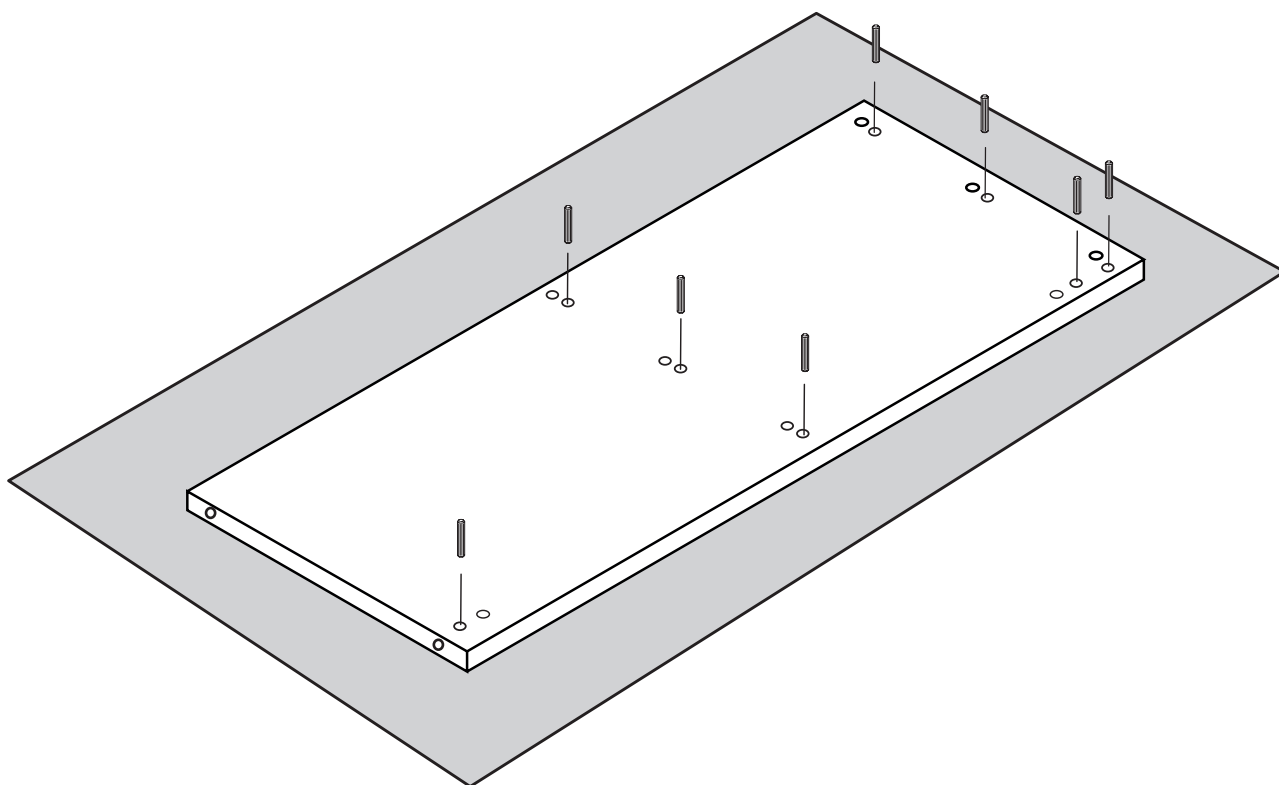
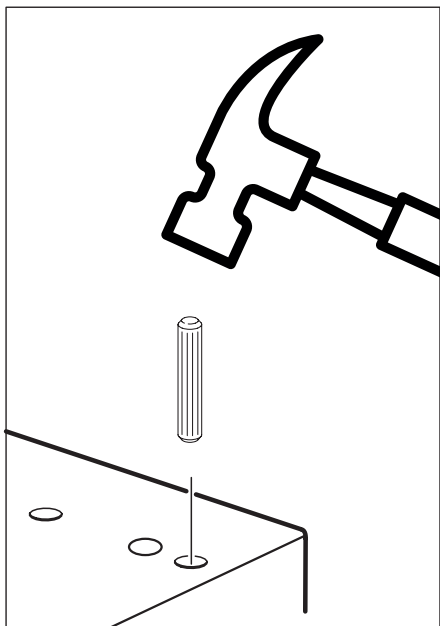

x8

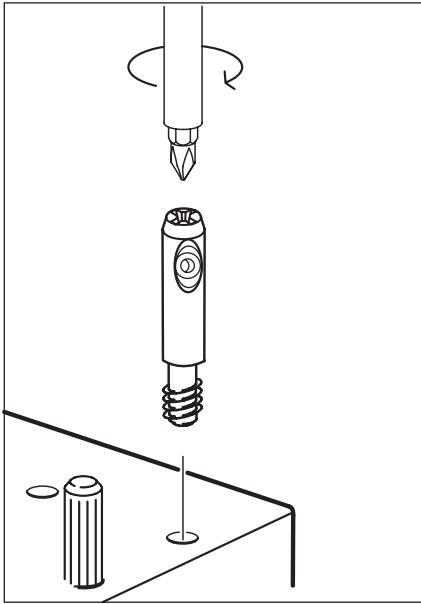

IT

Orientare il foro verso il pannello da agganciare nel passaggio successivo.

ENG

Orient the hole towards the panel to be attached in the next step.

FR

Orienter le trou vers le panneau à fixer dans l'étape suivante.

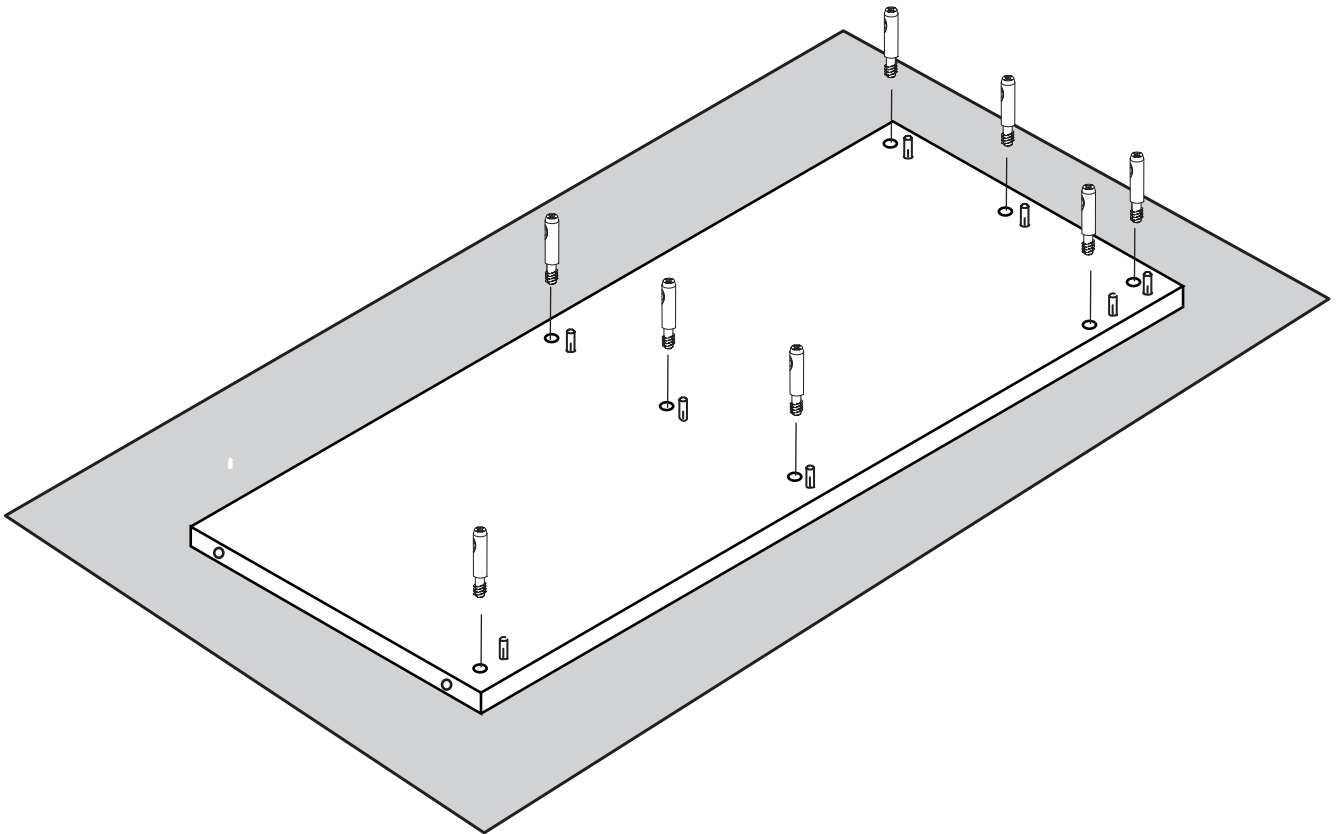

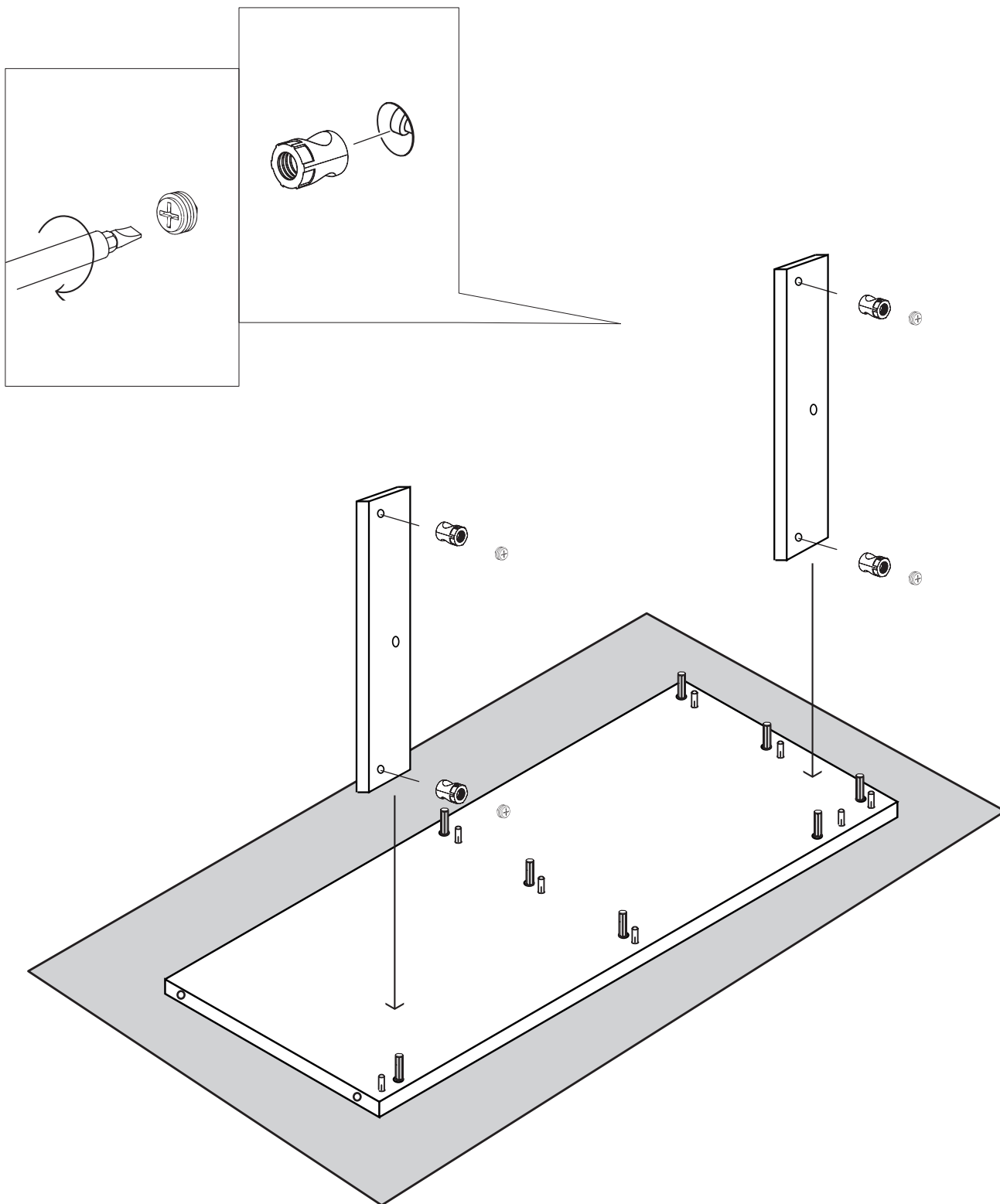

LAUNDRY SHELF - COLONNA H198
LAUNDRY SHELF - COLONNA

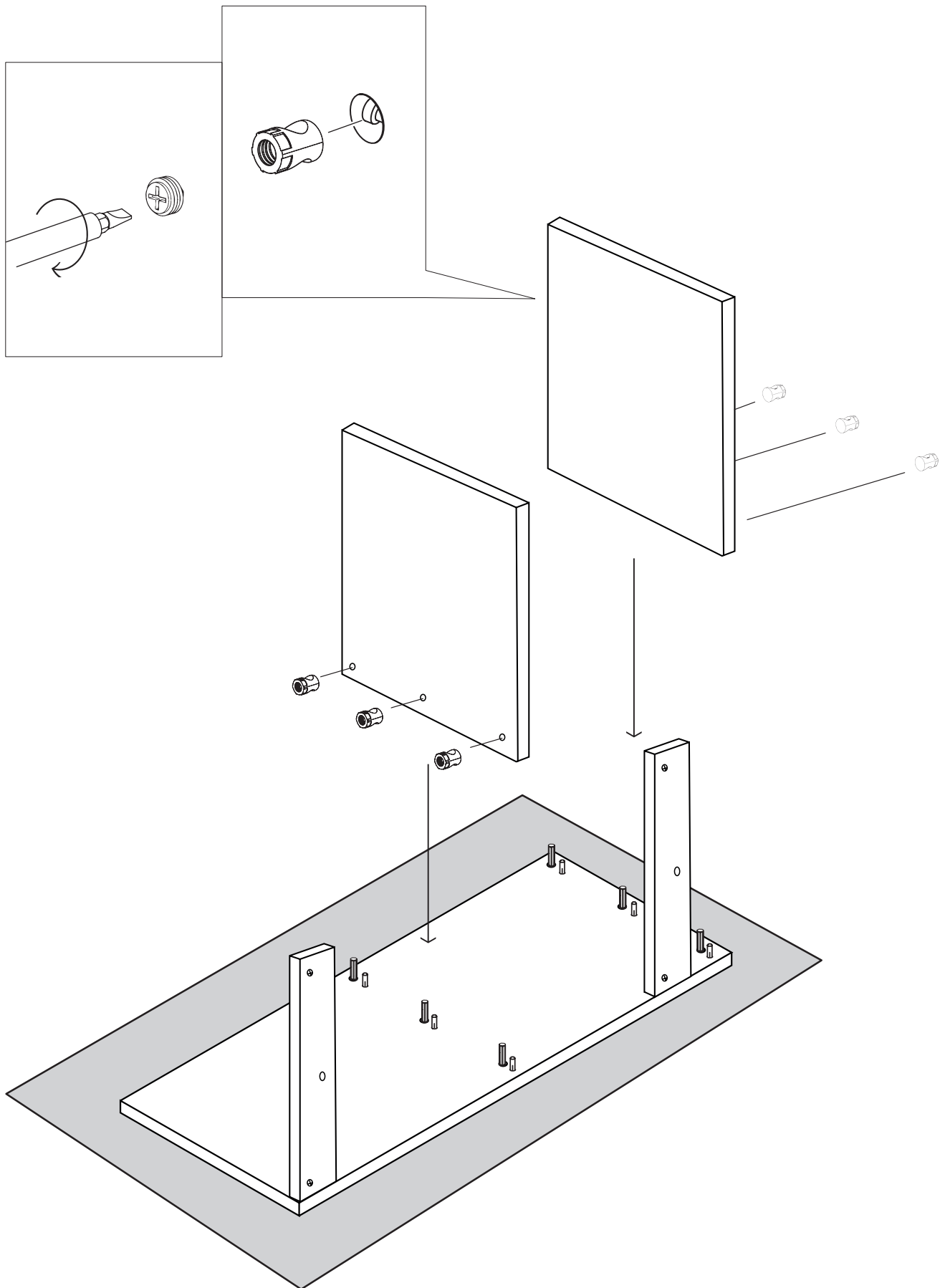

LAUNDRY SHELF - COLONNA H141
LAUNDRY SHELF - COLONNA

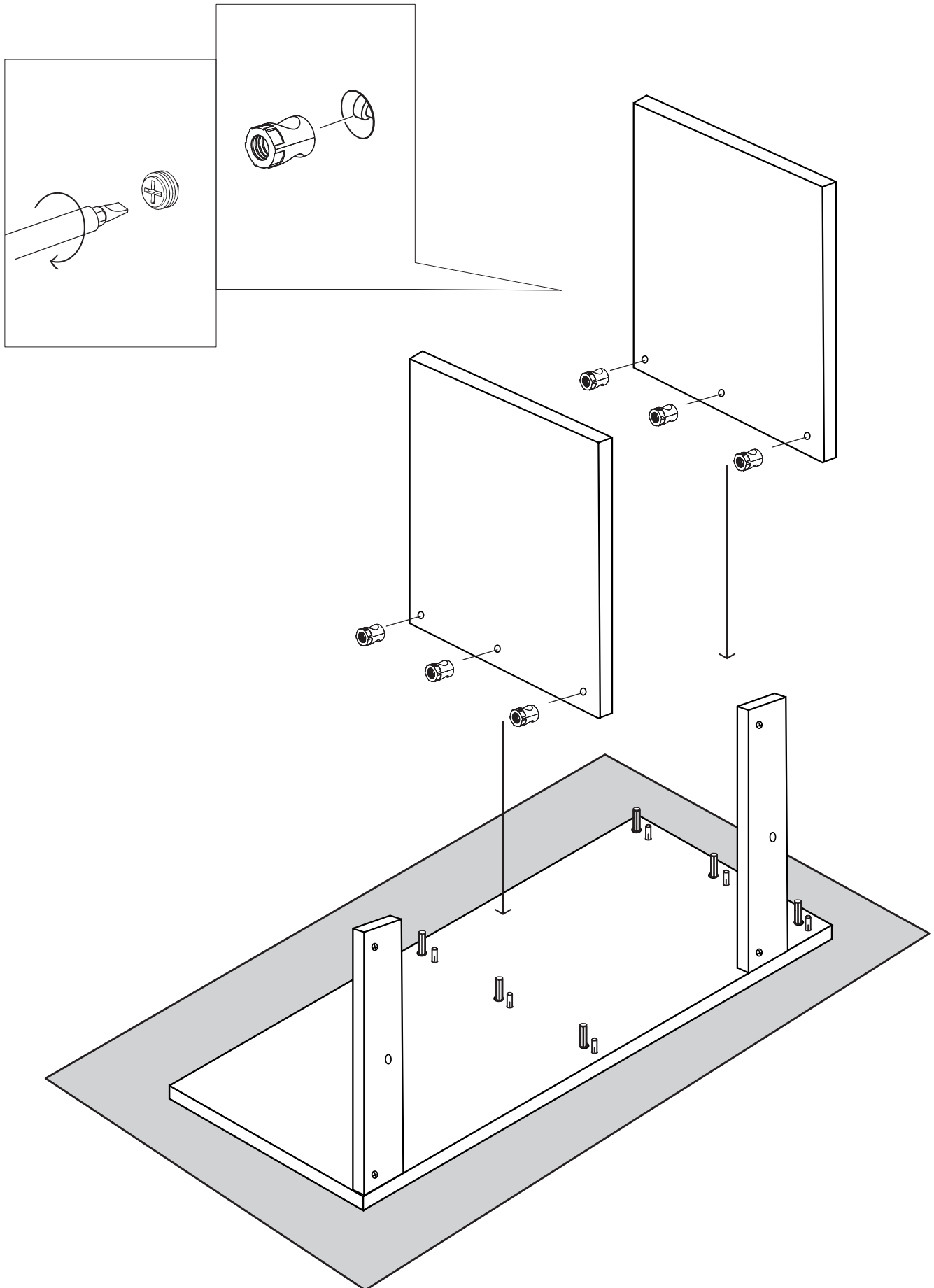

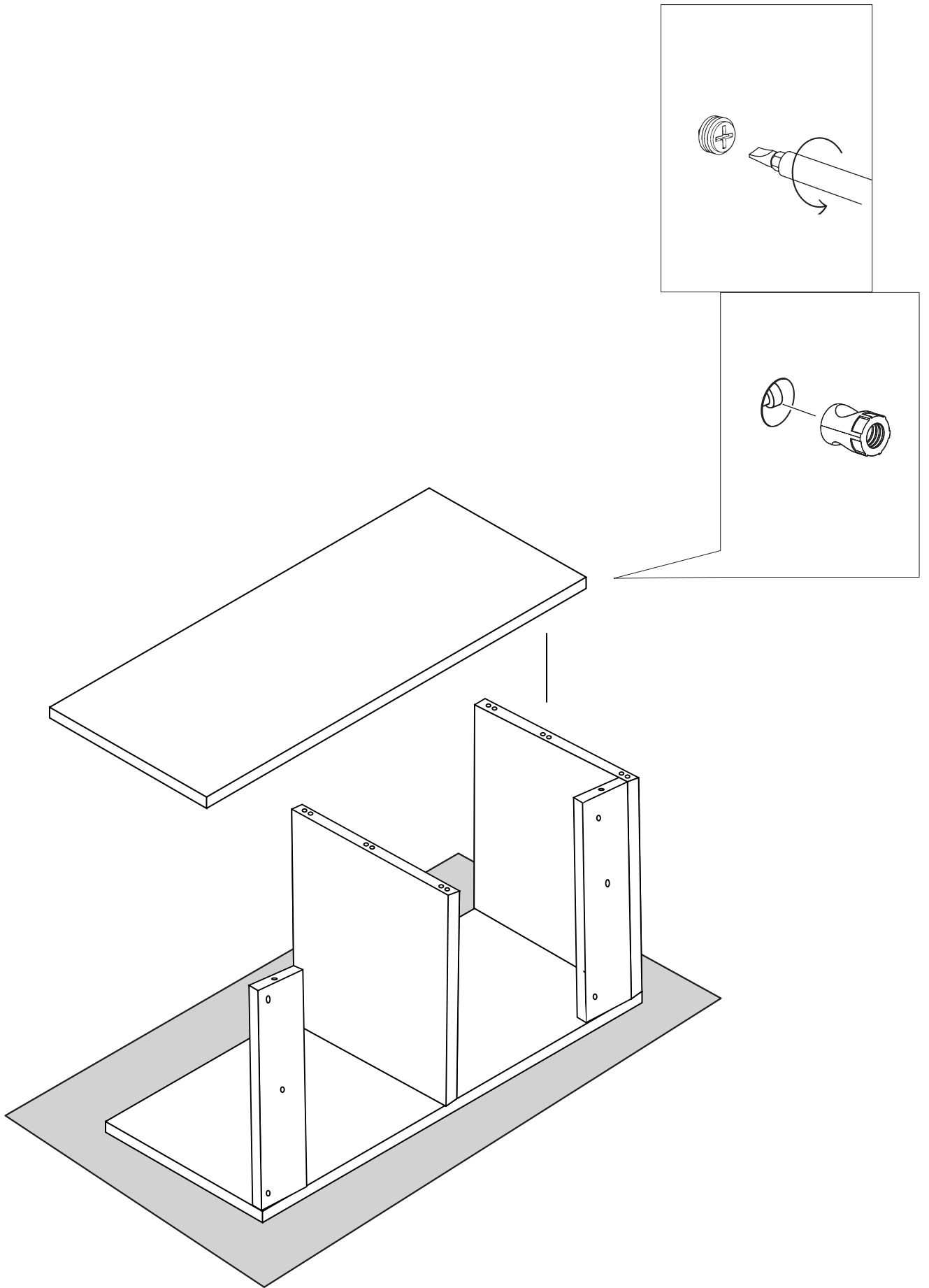

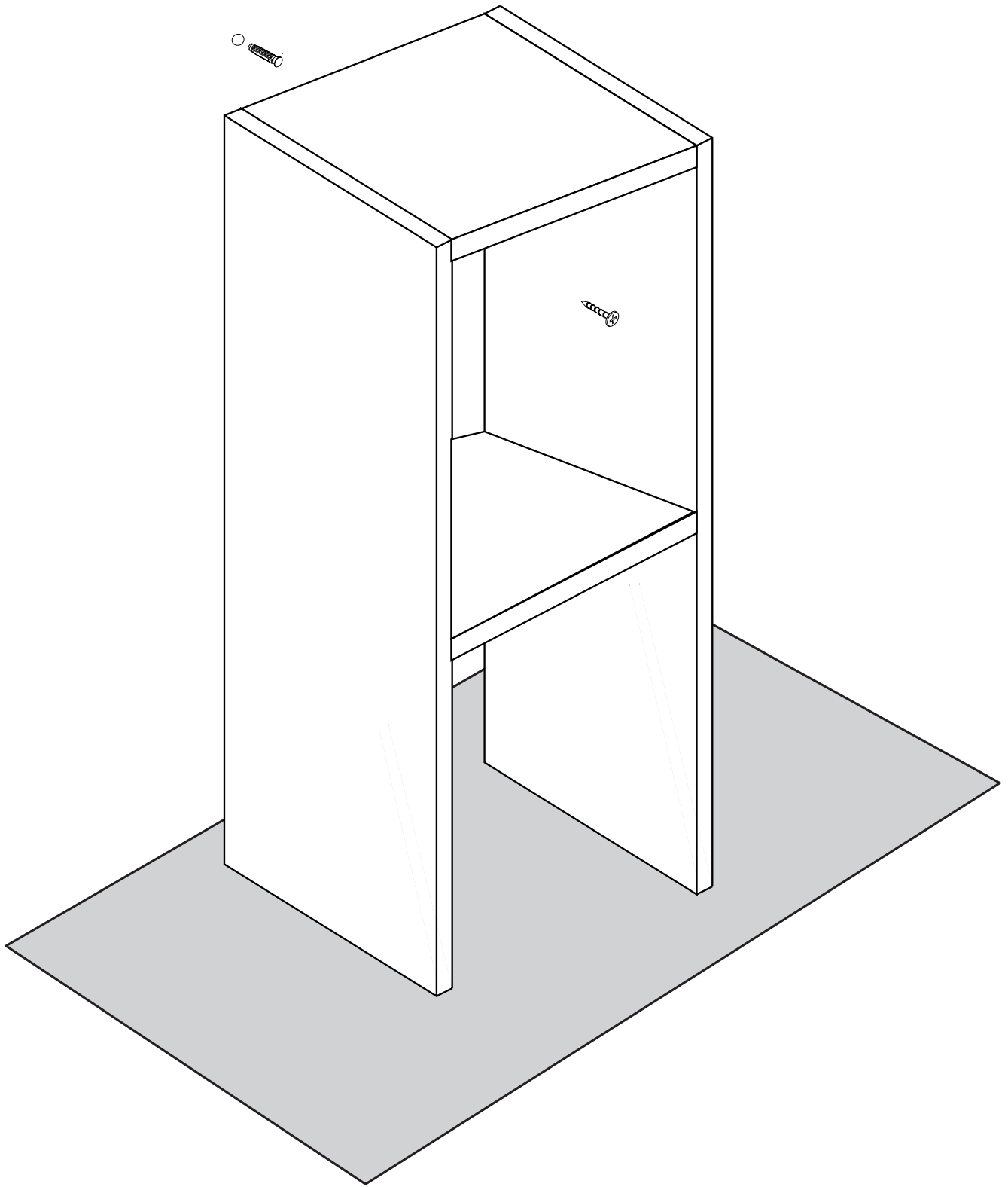

18.2 LAUNDRY SHELF - COLONNA H198 + KIT
LAUNDRY SHELF - COLONNA H198 + KIT

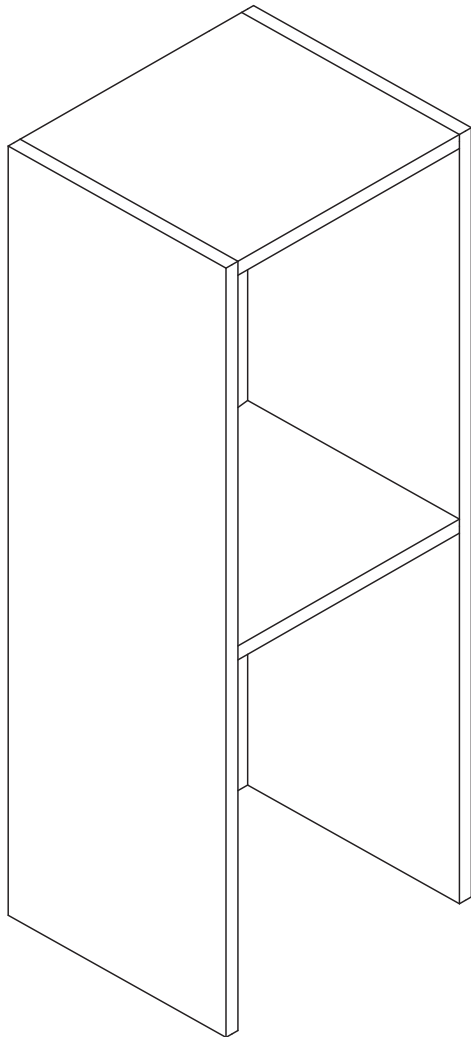

KIT 1

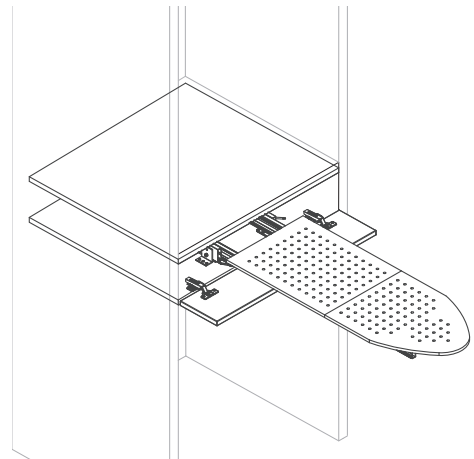

KIT 2

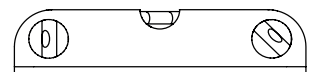
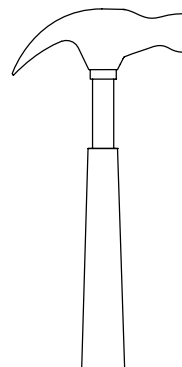
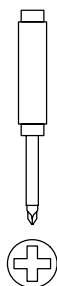
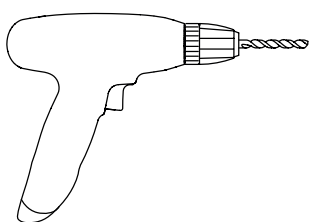
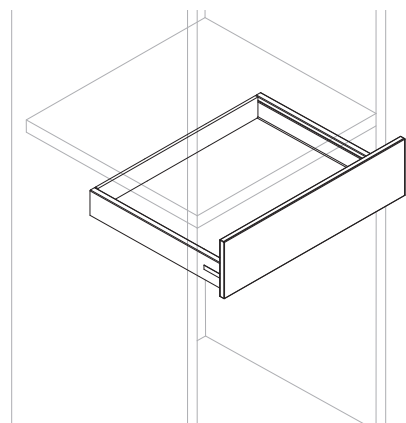

x2

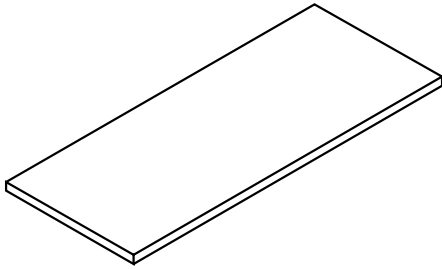

x2

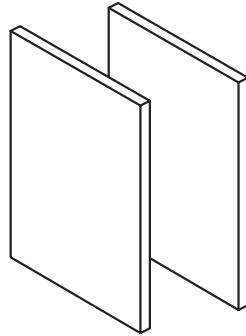

x2

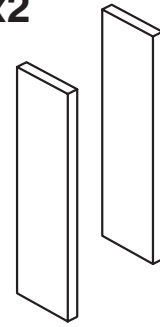

X4

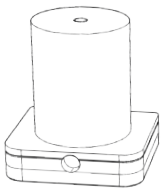

X12

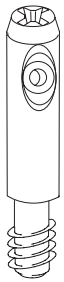

X4



X12

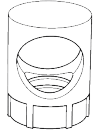

X12



X4

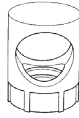

X4



X16

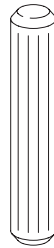

X8



X1

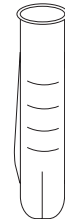

X1



X6



X4

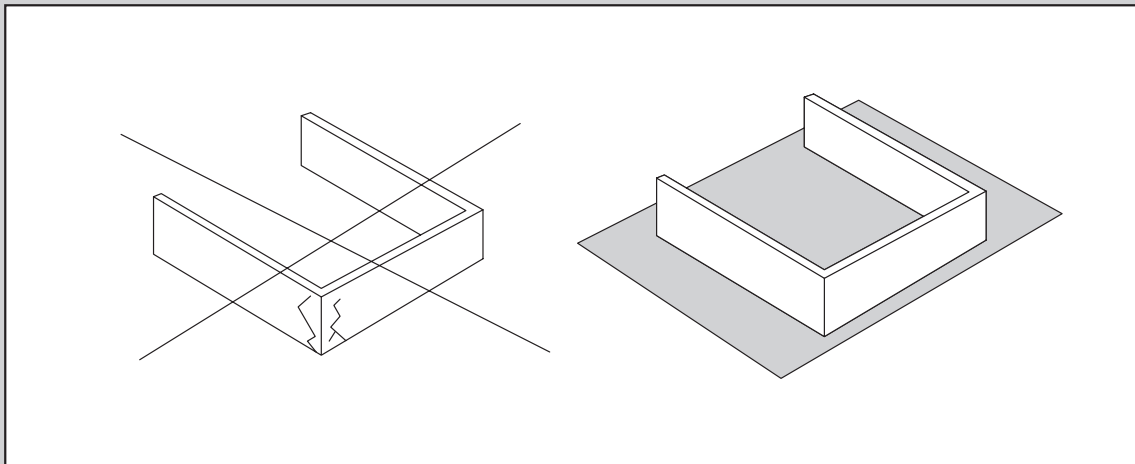

x8

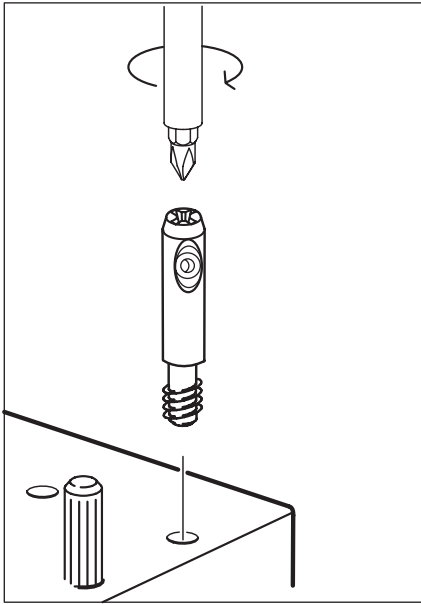

IT

Orientare il foro verso il pannello da agganciare nel passaggio successivo.

ENG

Orient the hole towards the panel to be attached in the next step.

FR

Orienter le trou vers le panneau à fixer dans l'étape suivante.

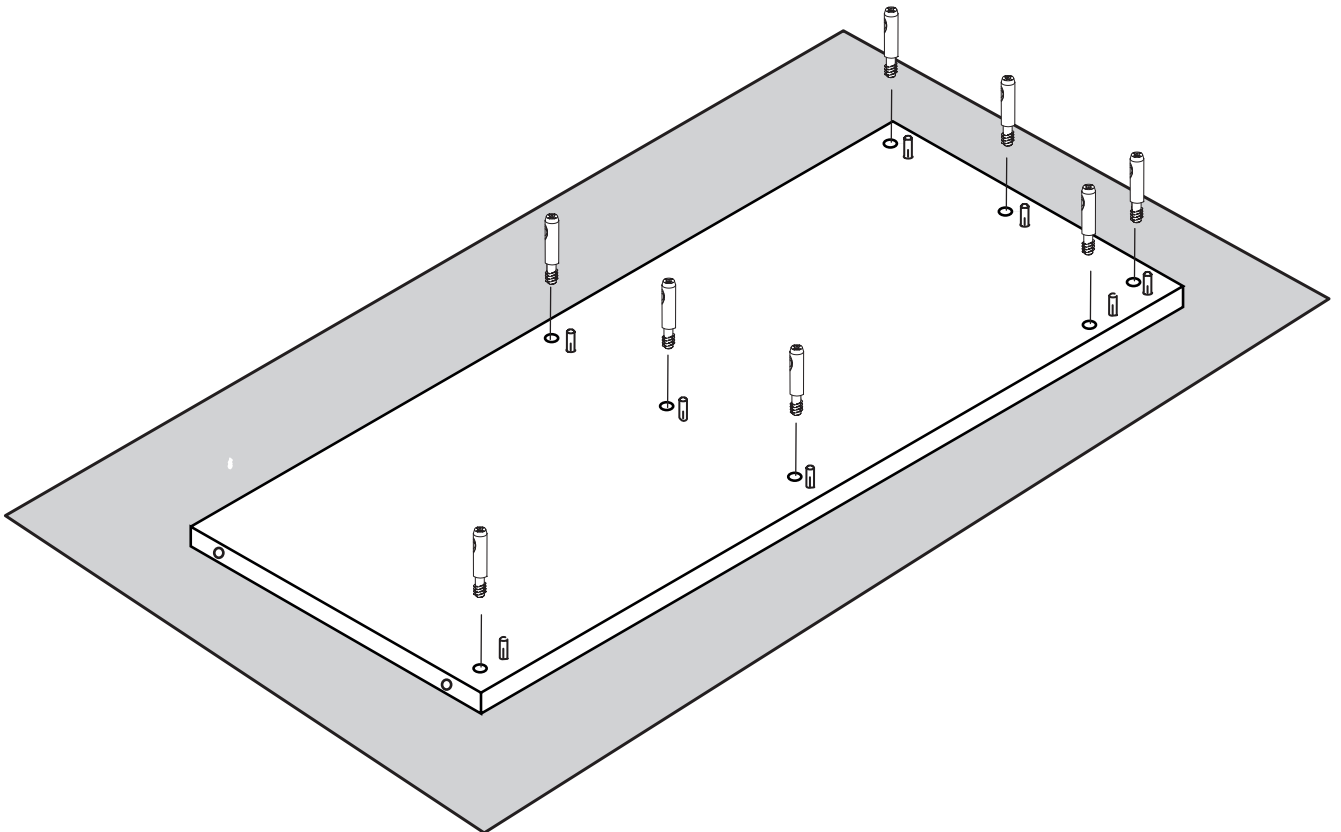

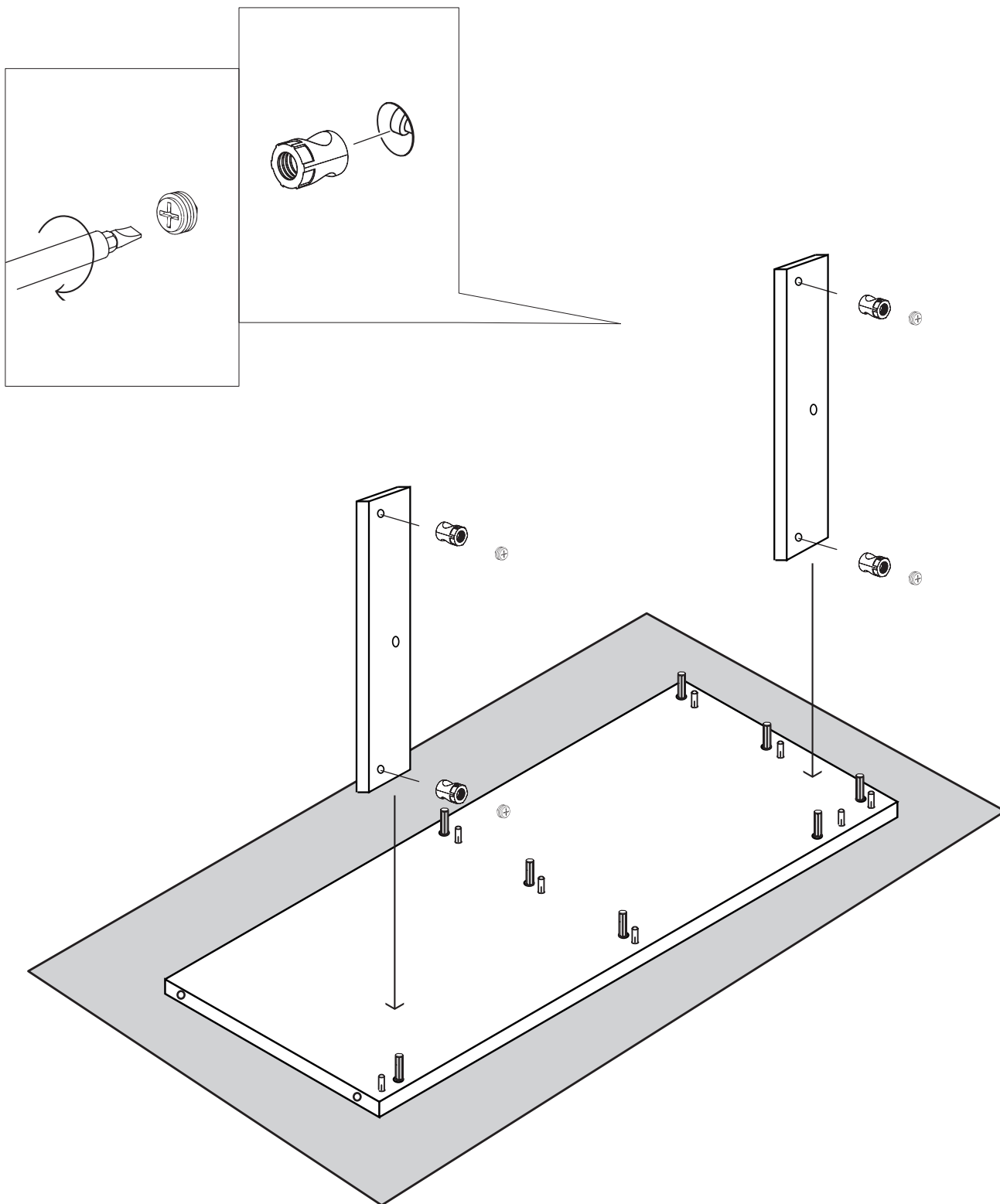

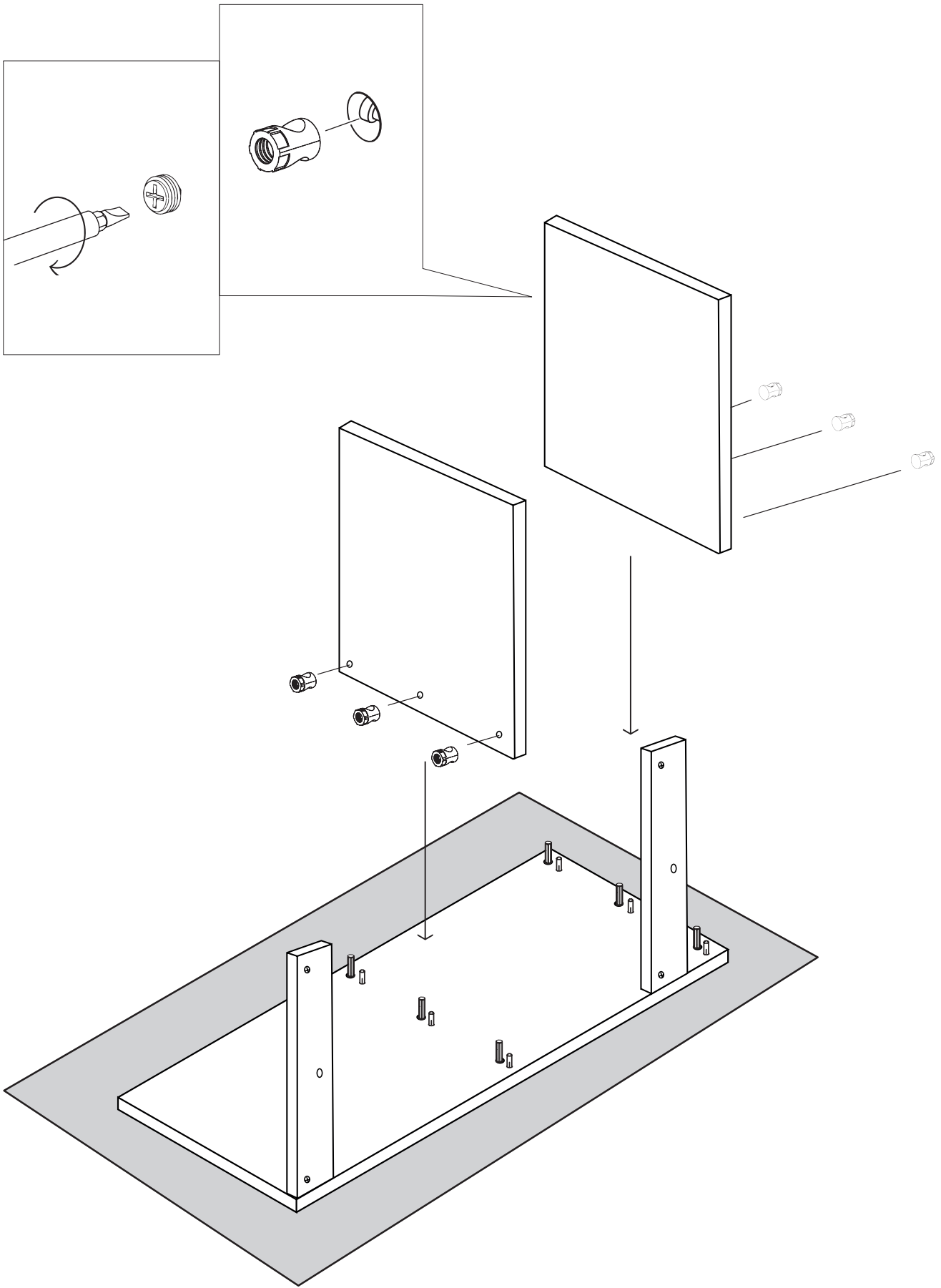

KIT 1

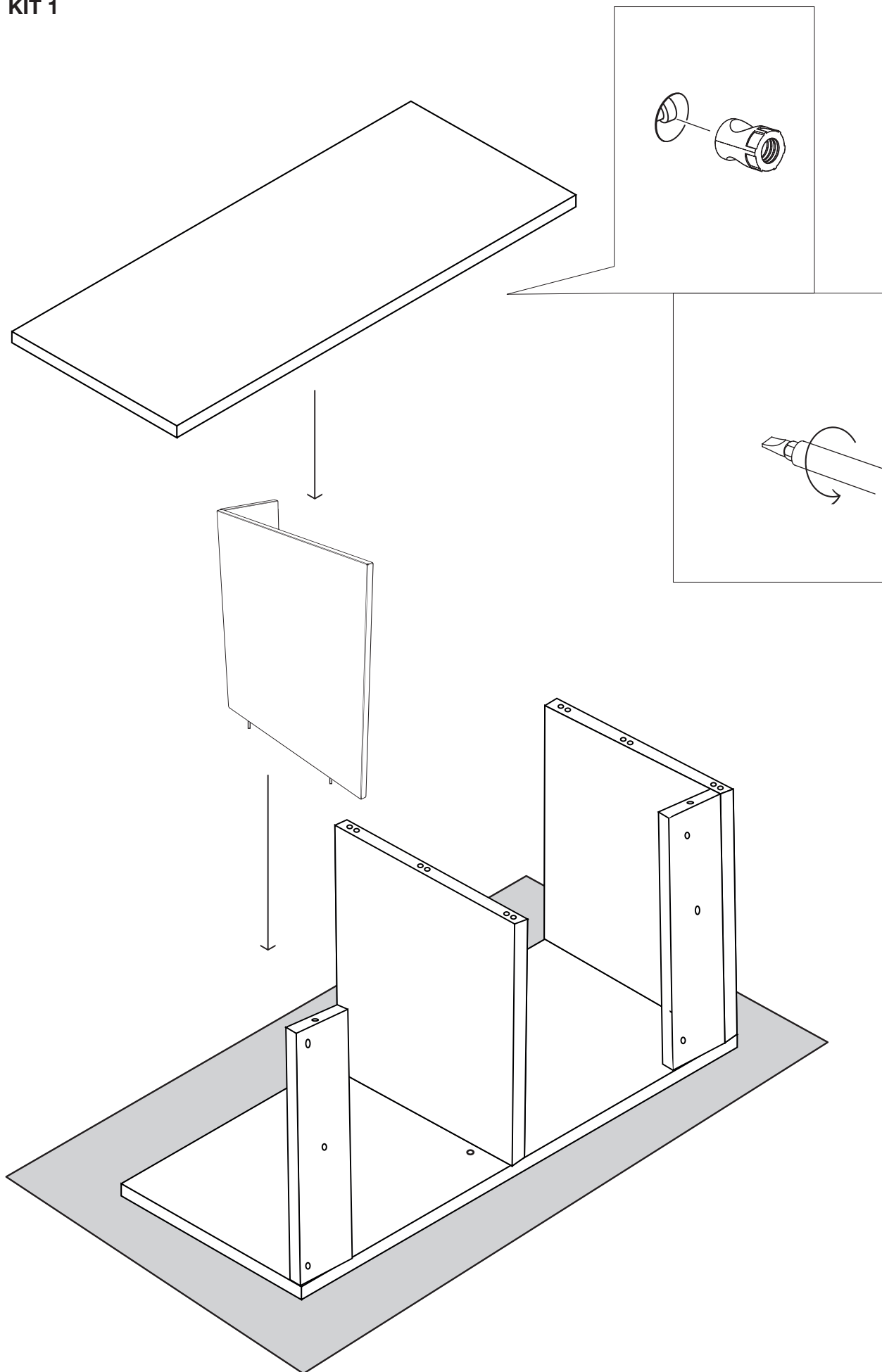

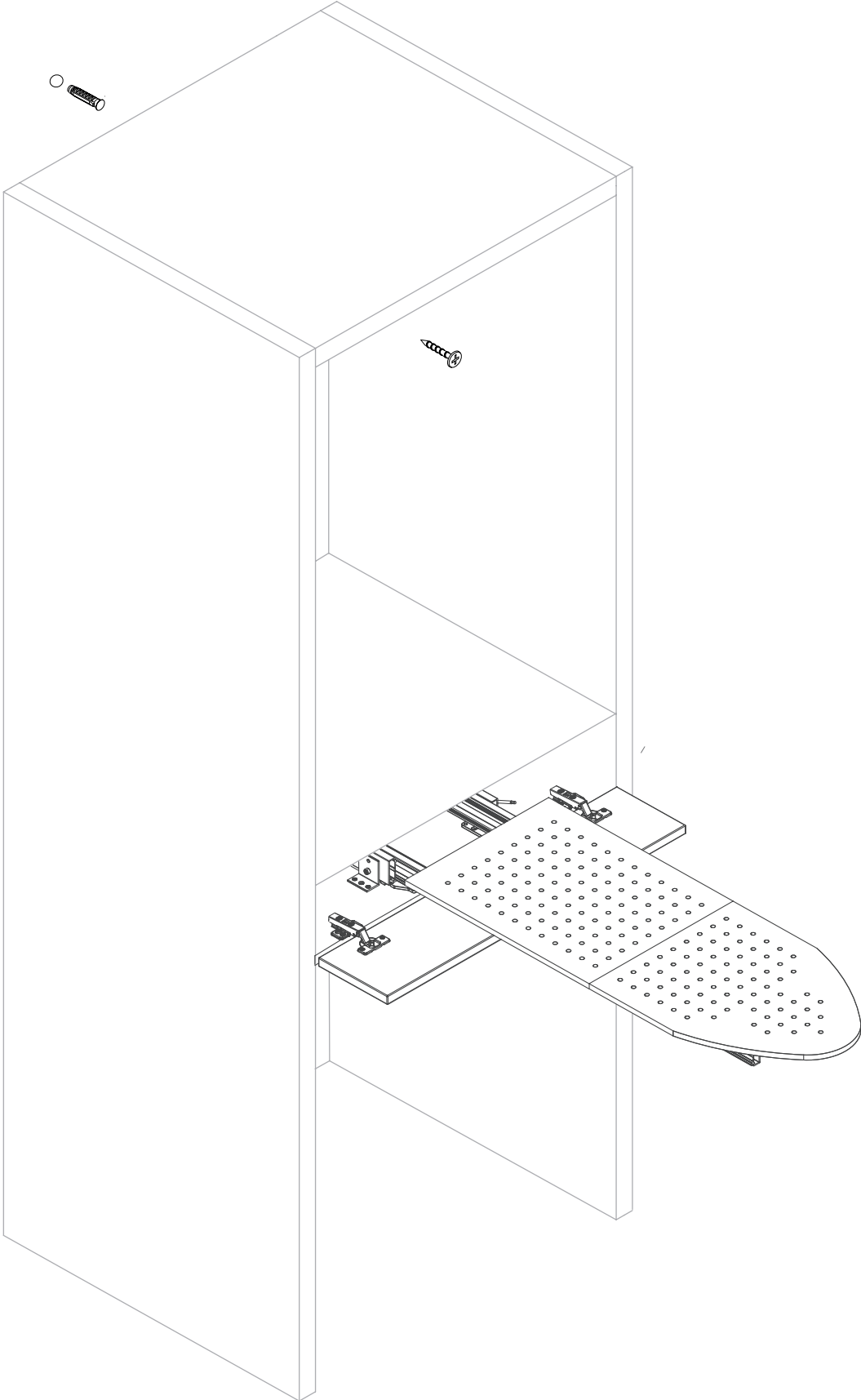

KIT 2

IT

Fissare le guide del cassetto su entrambi i fianchi

ENG

Attach the drawer guides to both sides.

FR

Fixer les glissières du tiroir sur les deux côtés.

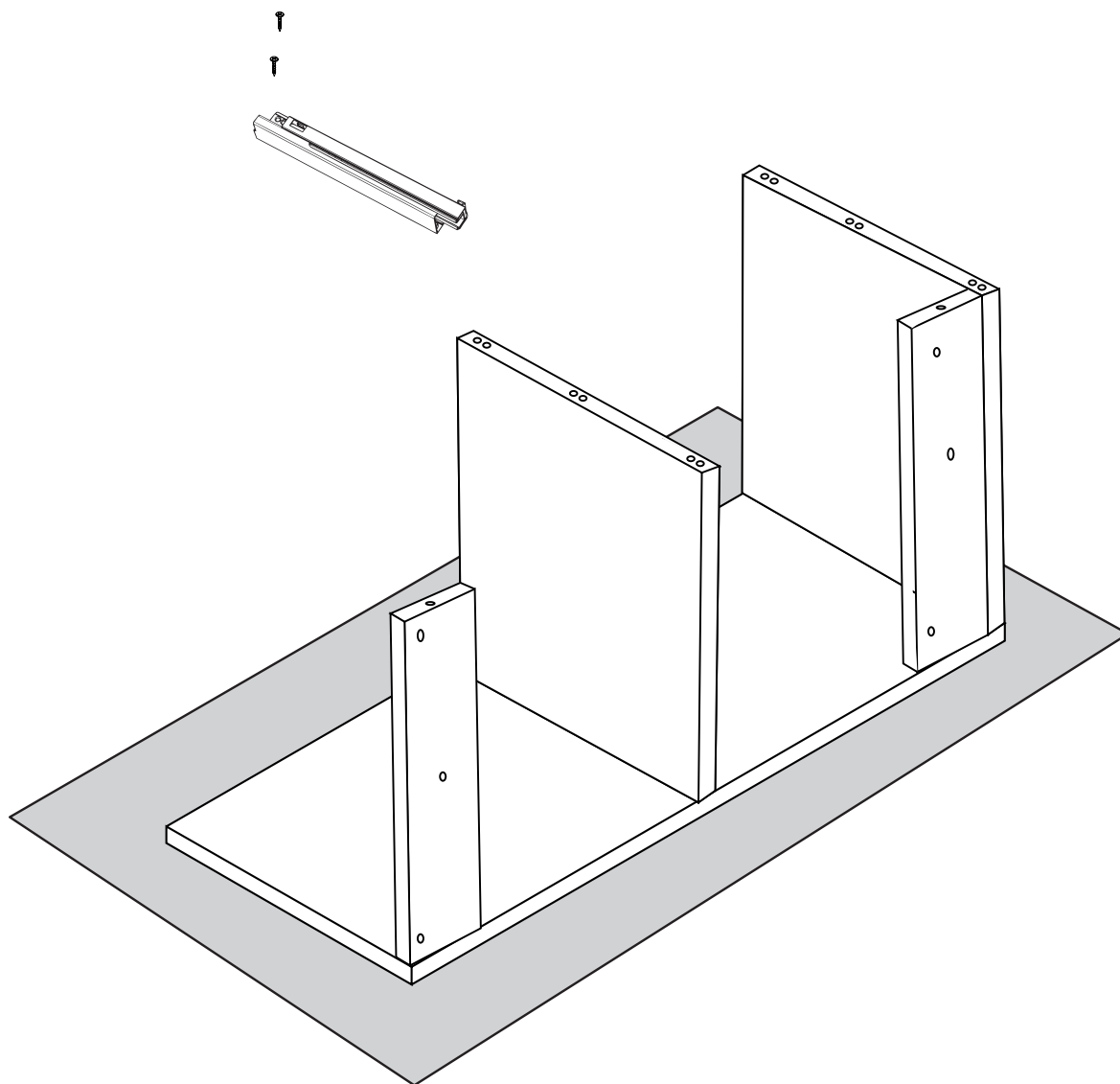

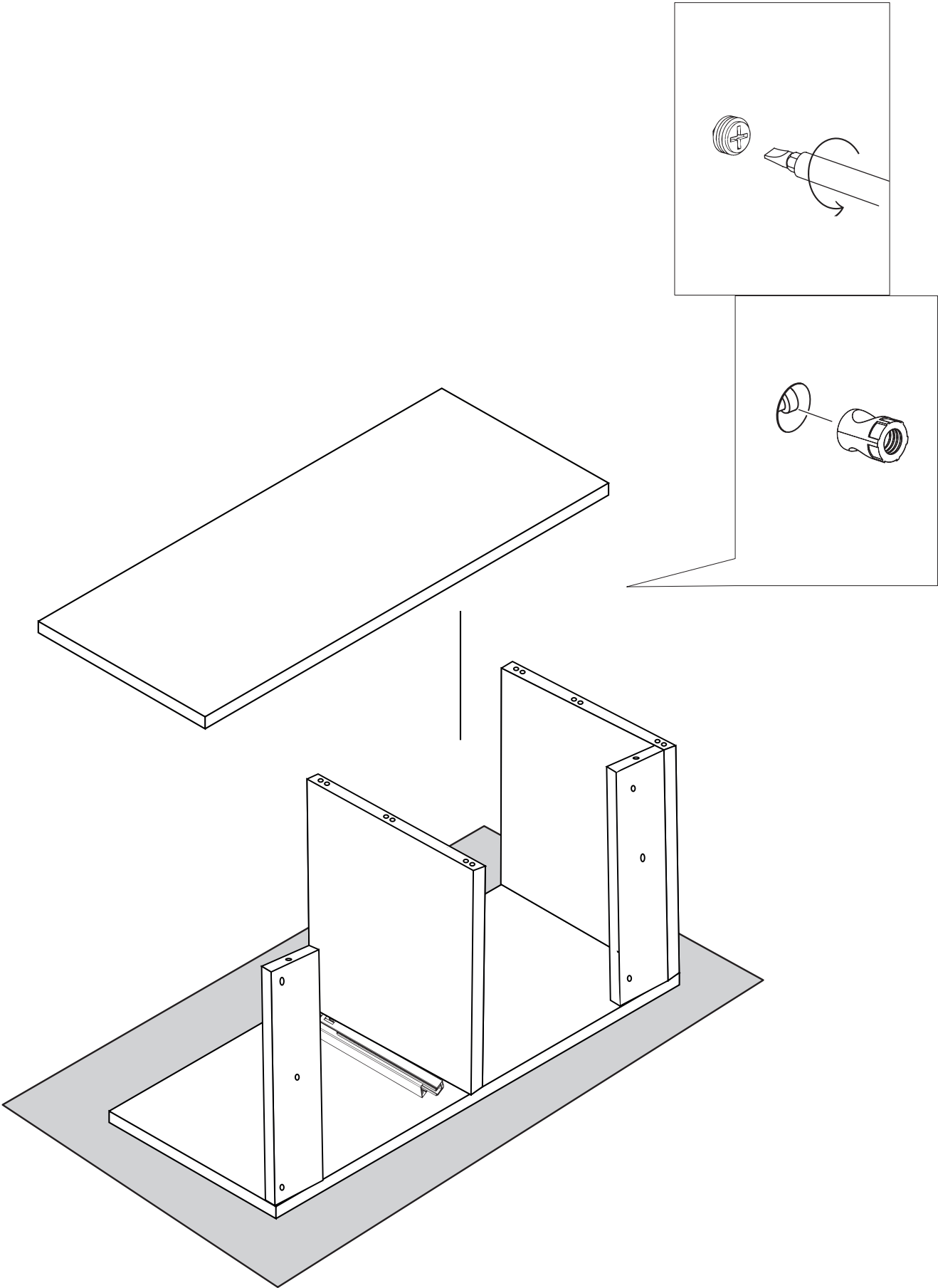

KIT 2

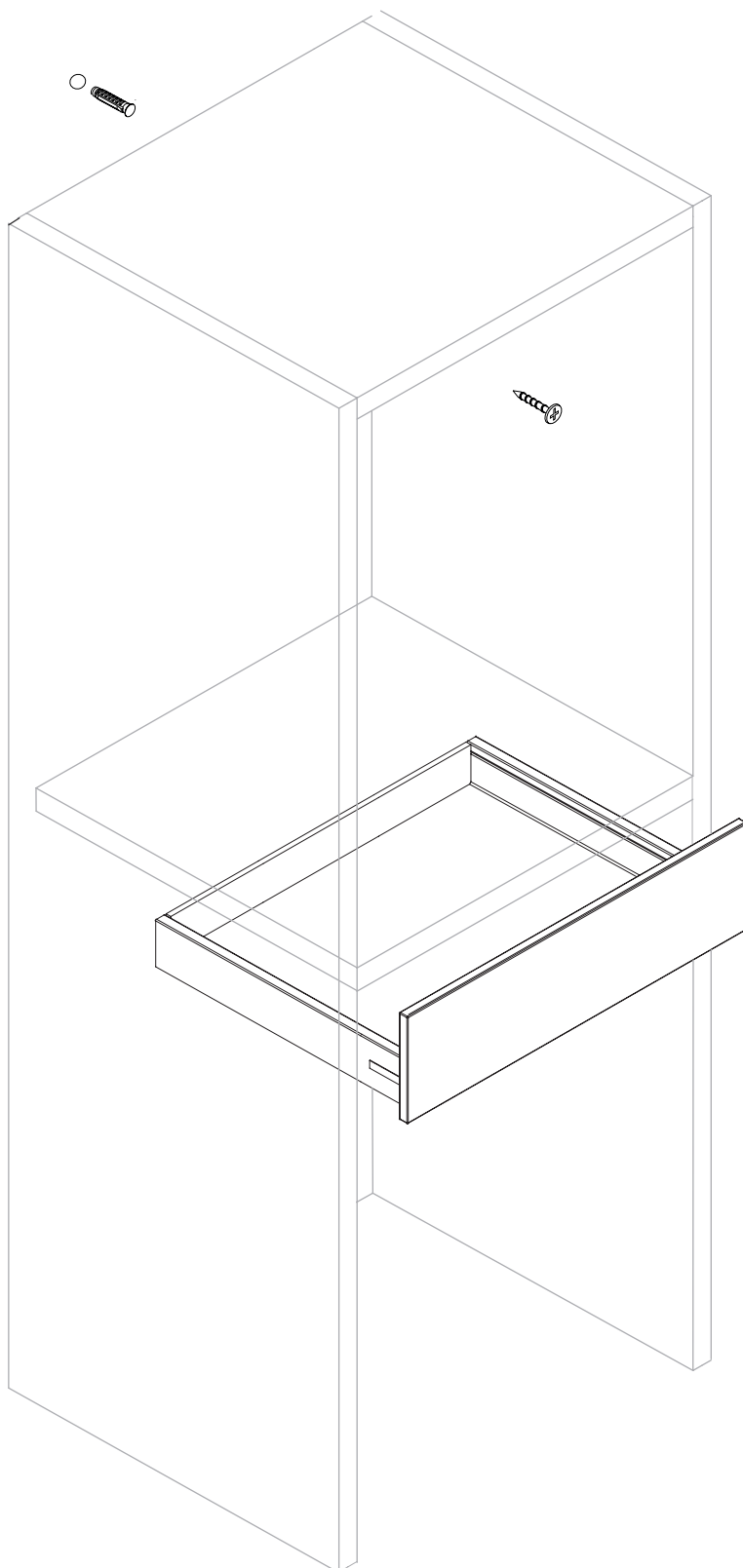

IT
inserire il kit cassetto una volta posizionata e fissata la colonna

ENG
Insert the drawer kit once the column is positioned and secured.

FR
Insérez le kit de tiroir une fois la colonne positionnée et fixée.

16. INFORMAZIONI AL CONSUMATORE

CONSUMER INFORMATION

SICUREZZA: Non apportare alcune modifiche ai mobili ed ai loro componenti onde evitare di comprometterne l'integrità, non destinare ad usi diversi da quelli previsti. Per l'installazione di mobili e complementi sospesi, dove previsto, utilizzare tasselli idonei alla parete di supporto. Tutti gli allacci elettrici vanno eseguiti a regola d'arte da personale qualificato.

ECOLOGIA: I prodotti in normali situazioni di utilizzo non risultano tossici o nocivi all'uomo, agli animali e all'ambiente, per il loro smaltimento non disperderli nell'ambiente ma affidarli, secondo le modalità previste, all'azienda comunale di smaltimento rifiuti.

USO E MANUTENZIONE: Non usare i mobili per fini diversi da quelli per cui sono progettati e dunque a titolo esemplificativo ma non esaustivo non arrampicarsi sopra gli stessi e non applicare pesi sulle ante, pulire con detergenti neutri e panno umido, evitare l'utilizzo di solventi e abrasivi. Si ricorda che le colorazioni, in particolare il bianco, subiscono nel tempo lievi variazioni soprattutto se esposte ai raggi solari o a fonti di luce diretta, di calore e a sostanze acido/corrosive. Tutti i mobili Xilon sono costruiti per essere installati ed utilizzati nella stanza da bagno, ambiente dove normalmente è presente un'umidità superiore agli altri locali. I nostri mobili sono realizzati in Pannello Ecologico idrofugo V100 legno melaminico a norma E1, le ante in legno melaminico ed in MDF rivestito in foglia polimerica. Si ricorda che i materiali idrorepellenti utilizzati riducono il rischio di assorbimento ma non lo eliminano (hanno una percentuale di rigonfiamento inferiore del 6% rispetto al legno melaminico non idro) quindi per preservare integro il Vostro mobile evitare ristagni di acqua ed asciugare dopo l'utilizzo, anche dopo le operazioni di pulizia.

SPECCHI: Per la pulizia degli specchi utilizzare esclusivamente alcool denaturato. Evitare l'utilizzo di prodotti particolarmente aggressivi che possano danneggiare l'argentatura nella parte posteriore dello stesso.

LAVABI IN CERAMICA: Aver cura di asciugare sempre le superfici utilizzando un panno morbido in microfibra per evitare la formazione di macchie di calcare. Per mantenere inalterate le caratteristiche della ceramica è sufficiente lavare regolarmente con acqua e un detergente non abrasivo (gel, crema o spray) a base di candeggina, utilizzando una spugna morbida non abrasiva, per eliminare residui di sapone e prevenire la formazione di calcare. Evitare l'utilizzo di detersivi abrasivi, alcool o detergenti a base acida/basica (ad esempio prodotti contenenti acido fluoridrico o soluzioni basiche come soda caustica), solventi nitrosi e acetone.

TOP E LAVABI IN Ocritech:

Ocritech lucido: Per la normale pulizia quotidiana dei piani lavo Ocritech lucido usare panni o spugne umidi e detersivi liquidi che non contengano particelle abrasive e risciacquare con acqua avendo cura di asciugarli con panni in microfibra. **NON** usare assolutamente detersivi abrasivi, alcool, acetone o altri tipi di solventi perché potrebbero danneggiare irrimediabilmente il prodotto. In caso di contatti accidentali con tali solventi risciacquare velocemente con acqua. Per mantenere brillante la superficie, applicare periodicamente del comune polish.

Ocritech opaco: Per la normale pulizia quotidiana dei piani lavo in Ocritech opaco usare una spugna tipo scotch brite e detersivi in polvere abrasivi, risciacquare con acqua avendo cura di asciugarli con panni in microfibra. **NON** usare assolutamente alcool, acetone o altri tipi di solventi perché potrebbero danneggiare irrimediabilmente prodotto. In caso di contatti accidentali con tali solventi risciacquare velocemente con acqua.

LAVABI IN ABS METACRILATO: Non usare nessun tipo di pasta sigillante per il montaggio del sifone e del troppo pieno; al limite può essere usato il silicone ma solo in caso in cui il vostro tecnico di fiducia lo ritenga opportuno. Evitare l'uso o utensili elettrici o pneumatici per serrare la componentistica del sifone. Per le operazioni di pulizia e uso non usare alcool, solventi, acidi e materiali abrasivi, si consigliano prodotti neutri multiuso. Evitare le alte fonti di calore (ferro da stiro caldo, sigarette ecc.) perché danneggerebbero irrimediabilmente il prodotto.

LAVABI IN POLIPROPILENE: Pulire i prodotti con acqua calda e panno morbido in microfibra, evitare prodotti che contengano il blu di metilene, poiché potrebbero macchiare irrimediabilmente la superficie del lavabo.

SAFETY: Do not make any changes to the units or to their components in order to avoid compromising their integrity. Do not use them for purposes other than those envisaged. For the installation of suspended units and complements, where envisaged, use suitable dowels on the support wall. All electrical connections must be carried out to a professional standard by qualified personnel.

ECOLOGY: The products in normal situations of use are not toxic or harmful to humans, to animals or to the environment. For their disposal do not disperse them in the environment but entrust them, in the manner provided, to the municipal waste disposal company.

USE AND MAINTENANCE: Do not use the units for purposes other than those for which they are designed and therefore, by way of example but not limited to, do not climb onto them and do not apply weights on the doors. Clean with neutral detergents and a damp cloth. Avoid the use of solvents and abrasives. It should be remembered that the colours, in particular white, undergo slight variations over time, especially when exposed to sunlight or direct light sources, heat and acid/corrosive substances. All the Xilon units are built to be installed and used in the bathroom, an environment where there is normally higher humidity than in other rooms. Our units are made of E1 standard melamine wood V100 Waterproof Ecological Panel, melamine wood doors and MDF coated in polymeric sheet. Remember that the water-repellent materials used reduce the risk of absorption but do not eliminate it (they have a swelling percentage lower than 6% compared to non-hydro melamine wood) so to keep your units intact, avoid water stagnation and dry after use, including after cleaning operations.

MIRRORS: To clean the mirrors use only denatured alcohol. Avoid using particularly aggressive products that could damage the silver plating on the back of the same.

CERAMIC WASHBASINS: Always dry the surfaces using a soft microfibre cloth to avoid the formation of limestone stains. To keep the characteristics of the ceramic unchanged, simply wash regularly with water and a non-abrasive detergent (gel, cream or spray) based on bleach, using a soft non-abrasive sponge, to eliminate soap residues and to prevent the formation of limescale. Avoid using abrasive detergents, alcohol or acid/base based detergents (e.g. products containing hydrofluoric acid or basic solutions such as caustic soda), nitrous solvents and acetone.

OCRITECHTOPS and WASHBASINS:

Glossy Ocritch: For normal daily cleaning of the glossy Ocritch tops, use wet cloths or sponges and liquid detergents that do not contain abrasive particles and rinse with water, being sure to dry them with microfibre cloths. **DO NOT** use abrasive detergents, alcohol, acetone or other types of solvents because they could irreparably damage the product. In case of accidental contact with such solvents rinse quickly with water. To keep the surface shiny, periodically apply everyday polish.

Matt Ocritch: For normal daily cleaning of the matt Ocritch tops, use a scotch brite sponge and abrasive powder detergents, rinse with water being sure to dry them with microfibre cloths. **DO NOT** use alcohol, acetone or other types of solvents because they could irreparably damage the product. In case of accidental contact with such solvents rinse quickly with water.

METHACRYLATE ABS WASHBASINS: Do not use any type of sealing paste for the assembly of the siphon and the overflow; silicone could in fact be used but only if your trusted technician deems it appropriate. Avoid using electrical or pneumatic tools or tools to tighten the siphon components. For cleaning and use operations do not use alcohol, solvents, acids and abrasive materials. Neutral multi-purpose products are recommended. Avoid high heat sources (hot iron, cigarettes etc.) because they would irreparably damage the product.

POLYPROPYLENE WASHBASINS: Clean the products with warm water and a soft microfibre cloth. Avoid products that contain methylene blue as they could irreparably stain the surface of the washbasin.

SÉCURITÉ: N'apportez aucune modification au meuble et à ses composants pour éviter de compromettre son intégrité, ne l'utilisez pas à des fins autres que celles prévues. Pour l'installation de meubles et accessoires suspendus, utiliser, le cas échéant, des chevilles adaptées au mur porteur. Tous les branchements électriques doivent être effectués de manière professionnelle par du personnel qualifié.

ÉCOLOGIE : Les produits en situations normales d'utilisation ne sont ni toxiques ni nocifs pour l'homme, les animaux ou l'environnement. Pour les éliminer, ne les jetez pas dans l'environnement mais confiez-les, selon les modalités établies, à l'entreprise municipale d'élimination des déchets.

UTILISATION ET ENTRETIEN : N'utilisez pas les unités à des fins autres que celles pour lesquelles elles ont été conçues et donc, à titre d'exemple mais sans s'y limiter, ne pas grimpez dessus et n'appliquez pas de poids sur les portes, nettoyez avec des détergents neutres et un chiffon humide. Évitez l'utilisation de solvants et d'abrasifs. Il convient de rappeler que les couleurs, en particulier le blanc, subissent de légères variations au fil du temps, en particulier si elles sont exposées au soleil ou à des sources de lumière directe, de chaleur et de substances acides/ corrosives. Tous les meubles Xilon sont conçus pour être installés et utilisés dans la salle de bains, un environnement où l'humidité est normalement plus élevée que dans les autres pièces. Nos meubles sont fabriqués en Panneau Écologique hydrofuge V100 de boisméla miné conforme aux normes E1, les portes sont en bois mélaminé et MDF recouverts de feuille polymère. N'oubliez pas que les matériaux hydrofuges utilisés réduisent le risque d'absorption mais ne l'éliminent pas (ils ont un pourcentage de gonflement inférieur à 6% par rapport au bois non hydro mélaminé) donc pour préserver votre meuble intact, évitez la stagnation de l'eau et séchez-le après utilisation y compris après les opérations de nettoyage.

MIROIRS : pour nettoyer les miroirs, utilisez uniquement de l'alcool dénaturé. Évitez d'utiliser des produits particulièrement agressifs qui pourraient endommager le placage argent au dos du produit.

LAVABO EN CÉRAMIQUE : Veillez toujours à sécher les surfaces à l'aide d'un chiffon doux en microfibre pour éviter la formation de taches de calcaire. Pour conserver inchangées les caractéristiques de la céramique, il suffit de la laver régulièrement avec de l'eau et un détergent non abrasif (gel, crème ou spray) à base d'eau de Javel, à l'aide d'une éponge douce non abrasive, pour éliminer les résidus de savon et éviter la formation de calcaire. Évitez d'utiliser des détergents abrasifs, des détergents à base d'alcool ou d'acide/base (par exemple des produits contenant de l'acide fluorhydrique ou des solutions basiques comme la soude caustique), des solvants nitreux et de l'acétone.

PLATEAU ET LAVABO EN OCRITECH :

Ocritech brillant : pour le nettoyage quotidien normal des plans de travail brillants Ocritech, utiliser des chiffons ou des éponges humides et des détergents liquides ne contenant pas de particules abrasives et rincer à l'eau en prenant soin de les sécher avec des chiffons en microfibres. NE PAS utiliser de détergents abrasifs, d'alcool, d'acétone ou d'autres types de solvants car ils pourraient endommager irrémédiablement le produit. En cas de contact accidentel avec ces solvants, rincer rapidement à l'eau. Pour garder la surface brillante, appliquez périodiquement du vernis ordinaire.

Ocritech mat : pour le nettoyage quotidien normal des plans de travail Ocritech mats, utiliser une éponge de type Scotch Brite et des détergents abrasifs en poudre, rincer à l'eau en prenant soin de les sécher avec des chiffons microfibres. N'utilisez absolument PAS d'alcool, d'acétone ou d'autres types de solvants car ils pourraient endommager irrémédiablement le produit. En cas de contact accidentel avec ces solvants, rincer rapidement à l'eau.

LAVABO EN MÉTHACRYLATE ABS : N'utilisez aucun type de pâte d'étanchéité pour l'assemblage du siphon et du trop-plein ; tout au plus du silicone peut être utilisé, mais seulement si votre technicien de confiance le juge approprié. Évitez d'utiliser des outils électriques ou pneumatiques pour serrer les composants du siphon. Pour les opérations de nettoyage et d'utilisation, ne pas utiliser d'alcool, de solvants, d'acides et de matériaux abrasifs, des produits neutres polyvalents sont recommandés. Évitez les sources de chaleur élevée (fer à repasser chaud, cigarettes, etc.) car elles endommageraient le produit de manière irréparable.

LAVABO EN POLYPROPYLENE : Nettoyez les produits avec de l'eau chaude et un chiffon doux en microfibre, évitez les produits contenant du bleu de méthylène, car ils pourraient tacher de manière irréparable la surface de l'évier.

XILON srl - Via Flaminia
Km. 58,200
Civita Castellana (VT)

info@xilon.it
+39 0761 540197
+39 0761 542055

www.xilon.it

